



**Seibu Electric & Machinery Co., Ltd.**

Industrial Machine Division  
3-3-1 Eki-higashi, Koga, Fukuoka 811-3193 Japan  
Tel: +81-92-941-1507  
Fax: +81-92-941-1517

**Head Office & Factory**

3-3-1 Eki-higashi, Koga, Fukuoka  
811-3193 Japan  
Tel: +81-92-941-1500  
Fax: +81-92-941-1511

**Tokyo Branch**

2-26-11 Kameido, Koto-ku, Tokyo  
136-0071 Japan  
Tel: +81-3-5628-0015  
Fax: +81-3-5628-0023

**Osaka Branch**

3-4-5 Umeda, Kita-ku, Osaka  
530-0001 Japan  
Tel: +81-6-4796-6711  
Fax: +81-6-4796-6707

**Nagoya Sales Office**

2-3101 Hara, Tenpaku-ku, Nagoya  
468-0015 Japan  
Tel: +81-52-800-5051  
Fax: +81-52-800-5030

**Kyushu Sales Office**

3-3-1 Eki-higashi, Koga, Fukuoka  
811-3193 Japan  
Tel: +81-92-941-1530  
Fax: +81-92-941-1522

**Hiroshima Sales Office**

2-2-9 Otemachi, Naka-ku, Hiroshima  
730-0051 Japan  
Tel: +81-82-545-1615  
Fax: +81-82-545-1618

**Sapporo Sales Office**

8-352 Kita Sanjo Higashi, Chuo-ku, Sapporo  
060-0033 Japan  
Tel: +81-11-221-0521  
Fax: +81-11-221-3392

**Sendai Sales Office**

17-22 Futsukamachi, Aoba-ku, Sendai,  
Miyagi 980-0802 Japan  
Tel: +81-22-797-6695  
Fax: +81-22-797-6696

**Tokyo Service Center**

1-13-2 Tajiri, Ichikawa, Chiba  
272-0014 Japan  
Tel: +81-47-378-7261  
Fax: +81-47-378-7266

**Osaka Service Center**

1-17 Nakasoujicho, Ibaraki, Osaka  
567-0803 Japan  
Tel: +81-72-630-5850  
Fax: +81-72-630-5852

**Nagoya Service**

2-3101 Hara, Tenpaku-ku, Nagoya  
468-0015 Japan  
Tel: +81-52-800-5051  
Fax: +81-52-800-5030

**Kyushu Service**

3-3-1 Eki-higashi, Koga, Fukuoka  
811-3193 Japan  
Tel: +81-92-941-1761  
Fax: +81-92-941-1522

<http://www.seibudenki.co.jp>

Please use the contact form on our website for inquiries.

Register via the website to download a variety of technical data.

We offer a wide range of options not described in this catalog. Contact one of our offices or agents for additional information.

# Valve Actuators

## General Catalog

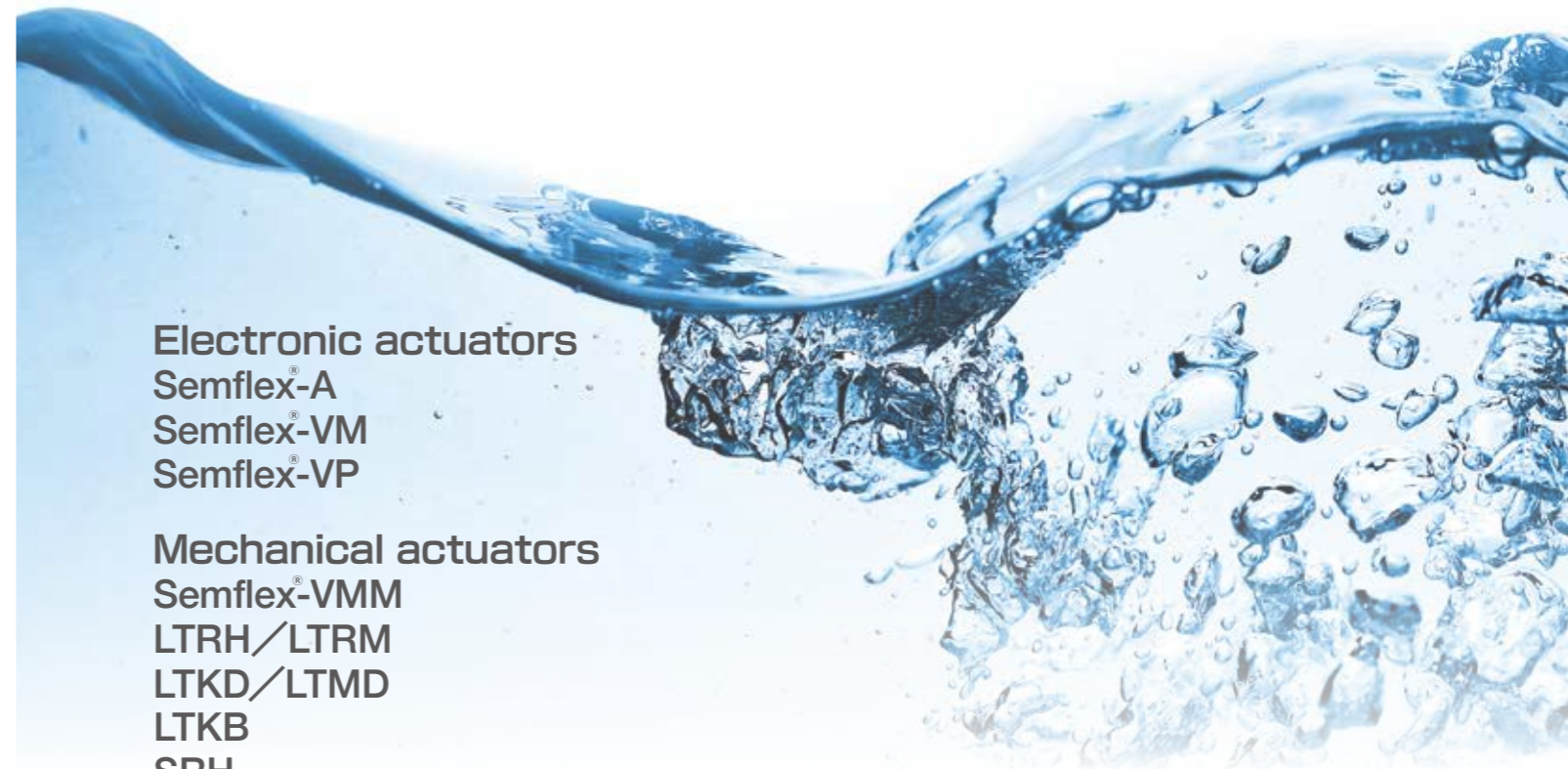

**Electronic actuators**

- Semflex®-A
- Semflex®-VM
- Semflex®-VP

**Mechanical actuators**

- Semflex®-VMM
- LTRH/LTRM
- LTKD/LTMD
- LTKB
- SRH
- SRJ

**Manual reducers**

- BRM





# Precise Flow Control

Water, electricity, gas, and petroleum: Vital elements that make our safe and comfortable lifestyle possible. And Seibu is working to ensure safe, accurate control worldwide.

Seibu began manufacturing valve actuators and gate drive mechanisms in 1954, recognizing their critical nature in bringing energy into our daily lives in the form of water, electricity, gas, and petroleum. We have pioneered a host of new industrial application fields and today we hold the top share of the Japanese market.

We will continue to meet the needs of an increasingly global world, applying unique technology and long experience in the field to provide customers with the optimal solutions.



Power plant



Sewage treatment plant



General factory equipment



Water purification plant



Gas plant



Rivers

## INDEX

Electronic	Introduction to electronic actuators	▶P3	Semiflex Type	
	Semiflex®-A series	▶P5	Semiflex A	
	Semiflex®-VM series	▶P7	Semiflex VM	
	Semiflex®-VP series	▶P9	Semiflex VP	
	PROFIBUS control system Package software	▶P11	PROFIBUS	
	Merits of intelligent system design	▶P12	Solution	
	AI Valve Control V-CON	▶P13		
	SBS [Seibu Backup System] Battery Backup System	▶P14		
	Mechanical	Mechanical types	▶P15	Mechanical types
		Semiflex-VMM series	▶P17	Semiflex VMM
LTRH/LTRM		▶P19	LTRH LTRM	
LTKD/LTMD series		▶P20	LTKD LTMD	
LTKB series		▶P24	LTKB	
SRH series		▶P25	SRH	
SRJ series		▶P26	SRJ	
Manual		BRM series	▶P27	BRM
		※Can be used as a valve secondary reducer		
Other		Actuator line-up	▶P29	Product line-up
	Support	▶P31	Support	
	Quality control	▶P33	Quality control	
	Request for quote	▶P34	RFQ	

# High-reliability actuators, electronically controlled for safe, powerful system operation.

Delivering environmental resistance, operability, and maintainability: Perfect for mission-critical systems

## 1 Compact, lightweight, simple construction offers excellent environmental resistance

Semflex<sup>®</sup> valve actuators with electronic sensors offer compact, lightweight, simple construction. Designed to fit into even tight spaces, they come with IP68-rated waterproofing and double sealing on terminals for unsurpassed environmental resistance.

○Explosion-proof specification also available as an option.

**Compliance standards**

- JIS
- CE Marking
- UL Standards

## 2 Simple settings and remote operation for top-class operability in set-up and adjustment

Our all-in-one construction integrates the control unit, for immediate operation after you power up. It comes with a rich array of fluid control functions, and an intuitive control panel for quick and easy set-up and adjustment.

○Remote operation also available as an option. For example, a single PC (master) can operate and monitor up to 125 actuators via PROFIBUS.

**Standard features**

- Electric value open/close
- LCD indicator
- Pushbutton limit switch and torque set (no need to open the cover)
- Manual/electric select switch (defaults to electric on auto-recover)

## 3 Fewer inspection items for faster maintenance and improved reliability

Semflex<sup>®</sup> is designed for fewer, simpler inspections and disassembly steps, slashing maintenance time and cost, and with the optional self-diagnosis function can predict required maintenance. Semflex<sup>®</sup> is the best choice for valve actuators in mission-critical systems!

**Seibu Electric & Machinery Flow-Flexible**  
 "Semflex" is a registered trademark of Seibu Electric & Machinery Co. Ltd.  
 "Sem" standard for Seibu Electric & Machinery.  
 "Flex" stands for Flow-Flexible.

## Semflex<sup>®</sup>-A series



Semflex-A50

Semflex-A50	Max. output torque: 50Nm/Max. thrust: 25kN Output speed min <sup>-1</sup> (50/60Hz): 1~100
Semflex-A100	Max. output torque: 100Nm/Max. thrust: 54kN Output speed min <sup>-1</sup> (50/60Hz): 1~100

IP 55	IP 67	IP 68	Limit switch	Torque switch	Interlock
Transmitter DC4~20mA output	Transmitter DC4~20mA I/O	Explosion-proof	PROFI BUS	Manual recovery	Automatic recovery

■ = Standard specification □ = Not available ▨ = Option

※Detail specifications available on request.

## Semflex<sup>®</sup>-VM series



Semflex-VM-01

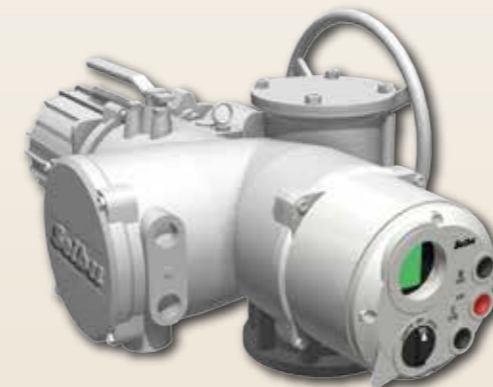

Semflex-VM-07

<b>New</b> Semflex-VM-007	Max. output torque: 70Nm/Max. thrust: 70kN Output speed min <sup>-1</sup> (50/60Hz): 11.3/13.5~75.9/91.1
Semflex-VM-01	Max. output torque: 150Nm/Max. thrust: 70kN Output speed min <sup>-1</sup> (50/60Hz): 11.3/13.5~75.9/91.1
Semflex-VM-04	Max. output torque: 550Nm/Max. thrust: 130kN Output speed min <sup>-1</sup> (50/60Hz): 11.3/13.5~75.9/91.1
Semflex-VM-07	Max. output torque: 850Nm/Max. thrust: 160kN Output speed min <sup>-1</sup> (50/60Hz): 11.3/13.5~75.9/91.1
Semflex-VM-1	Max. output torque: 1800Nm/Max. thrust: 270kN Output speed min <sup>-1</sup> (50/60Hz): 11.3/13.5~75.9/91.1

IP 55	IP 67	IP 68	Limit switch	Torque switch	Interlock
Transmitter DC4~20mA output	Transmitter DC4~20mA I/O	Explosion-proof	PROFI BUS	Manual recovery	Automatic recovery

■ = Standard specification □ = Not available ▨ = Option

※Detail specifications available on request.

## Semflex<sup>®</sup>-VP series



Semflex-VP-010

Semflex-VP-010	Max. output torque: 125Nm Open/close speed sec/90° (50/60Hz): 9/7.5·18/15
Semflex-VP-020	Max. output torque: 250Nm Open/close speed sec/90° (50/60Hz): 18/15·36/30
Semflex-VP-060	Max. output torque: 600Nm Open/close speed sec/90° (50/60Hz): 18/15·36/30
Semflex-VP-1	Max. output torque: 1000Nm Open/close speed sec/90° (50/60Hz): 18/15·36/30
Semflex-VP-2	Max. output torque: 2000Nm Open/close speed sec/90° (50/60Hz): 36/30·72/60

IP 55	IP 67	IP 68	Limit switch	Torque switch	Interlock
Transmitter DC4~20mA output	Transmitter DC4~20mA I/O	Explosion-proof	PROFI BUS	Manual recovery	Automatic recovery

■ = Standard specification □ = Not available ▨ = Option

※Detail specifications available on request.



# The world's smallest power actuator

Semflex<sup>®</sup>-A series actuators have on-board servomotors, delivering the same high-speed valve open/close performance as air actuators. The small, light design is perfect for installation in maintenance pits or other tight spaces.



### Features

- Small, lightweight design about the size of a sheet of paper.
- A/B gears used in conventional designs have been eliminated, slashing operating noise to no more than 50 db.
- Smaller actuator simplifies pipe design, and helps downsize plants overall.
- Servomotor speed control enables variable sleeve speed of 1~100min<sup>-1</sup>.
- SURFDRIVE (minimal motor shaft vibration) function increases internal gear efficiency.
- Valve interface complies with ISO5211.

### Applications

- Valves
- Gate valves
- Gates (flow control)

### Controller specifications

Function	Specification
Actuator type	Intelligent (internal motor drive)
Main power supply	AC 200V/400V class
Manual handle	Handle directly linked to motor shaft (manual power loss reduction)
Manual switch	Depress handle (manual operation recovery, interlocked)
Position indicator	LCD display (international icons)
Power control	Pushbutton switches (contactless)
Settings	Set from control panel (non-intrusive)
Position detection	Resolver encoder (maximized reliability)
Torque detection	Intelligent detection (improved accuracy)
External interface	Terminal block type Plug-in connector (reduced-volume)
Standards compliance	CE, UL, JIS, NK

### Specifications

Model	Max. output torque (Nm)	Max. thrust (kN)	Flange size	Max. shaft dia. (mm)		Output speed min <sup>-1</sup> (50/60 Hz)	Motor		Mass (kg)
				Rod	Screw		Power supply	Output kW	
Semflex-A-50	50	25	F07	28	30	1~100	Three-phase 200V class	0.4	24
Semflex-A-100	100	54	F10	38	40		Three-phase 400V class	0.75	25

### Dimension drawings

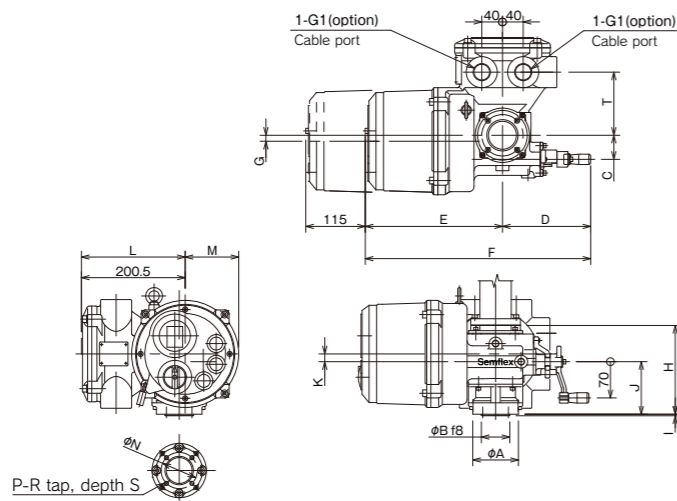

### Dimensions

形式	φA	φB	C	D	E	F	G	H	I	J	K	L	M	φN	P	R	S	T
Semflex-A-50	90	55	47	171	265	436	12	172	3	102	15	201	104	70	4	M8	12	122
Semflex-A-100	125	70	50	175	270	445	14	177	3	97	16	206	104	102	4	M10	17	125

※Please inquire for special installation or environmental requirements. (Vibration:Mechanism 1G max.,electrical components exceeding 0.5G, noise,etc).

## A series Butterfly valve implementation

Model:Semflex<sup>®</sup>-A-50 / BRM-3F

1. Motor operation  
Via the actuator panel (standard equipment)
2. Setting open/close limits and torque  
Settable with pushbutton switches.
3. Actuator status check  
Position, torque alarm and other status information can be checked on the LCD.

### Operation panel



### List of models by pipe diameter (reference values)

Model	Applicable butterfly valves (mm)	Applicable gate valves (mm)
A-50	50~350	50~100
A-100	250~400	100~150



Note:We do not manufacture or sell valves.

## Sample Semflex<sup>®</sup>-A / BRM installation



### Description

Installed as power actuator for an emergency cut-off on the wastewater path for a pharmaceuticals firm.

### User requirements

Previously an air actuator was used to open and close this emergency cut-off valve, but the user wanted a rapid-action power valve that could be installed in a narrow pit.

### Solution proposal

The Semflex-A series of power valve actuators with inboard servomotors was proposed, offering the same high-speed open/close action as air actuators. The power valve actuator is the smallest in the world, facilitating installation in a narrow pit.



## Computerized actuators for even large-diameter pipes

Semflex®-VM actuators, available with optional on-board inverter function, can handle variable open/close speeds, as well as offering a valve purge function, and water-hammer prevention design.



### Features

- Small, lightweight design (about half the mass of our prior model).
- IP68-rated waterproofing and double sealing on terminals to minimize faults caused by liquid penetration.
- Valve operation possible immediately after supplying power.
- Supports wide range of operation (water-hammer prevention, valve purge, torque retry, etc.).
- On-board inverter (option) to adjust open/close speed.
- 2-wire PROFIBUS communication network (option) can be easily added.
- Supports a variety of remote functions. Wireless communication means operation from anywhere, with simple status monitoring.
- Explosion-proof ExdII BT4 construction (option).
- Valve interface complies with ISO5211.

### Applications

- Valves
- Gate valves
- Gates (flow control)

### Controller specifications

Function	Specification	Remarks
Main power supply	Three-phase AC 200V/400V class	Inquire for alternate power supplies
Control CPU	16-bit CPU with ADC and DAC, 16-MHz clock	
Position detection	Electronic absolute encoder, 16 pulse	
Torque detection	±5% precision	Worm motion sensing (contactless potentiometer)
LCD	Position (% open), fault icons, indicator, 3-character data	Displays with main power off
Basic operation	Open, stop, and close pushbuttons; Local/remote	
Adjustable open/close speed	Inverter (option)	
Position set	0%, 100%, and 4 intermediate user-defined points	User-definable within encoder count range
Torque set	User-adjustable between 30% and 100%	
Options	Inverter proportional control (stepless positioning), fieldbus support (PROFIBUS-DP), self-diagnosis	

### Specifications

Model	Max. output torque (Nm)	Max. thrust (kN)	Flange size	Max. shaft dia. (mm)		Output speed min <sup>-1</sup> (50/60 Hz)	Motor	
				Rod	Screw		Power supply	Output kW
Semflex-VM-007	70	70	F10	34	40	11.3/13.5~75.9/91.1	Three-phase 200V class	0.1, 0.2
Semflex-VM-01	150	70	F10	34	40	11.3/13.5~75.9/91.1		0.2, 0.4, 0.75
Semflex-VM-04	550	130	F14	50	58	11.3/13.5~75.9/91.1		0.75, 1.5, 2.2
Semflex-VM-07	850	160	F16	60	72	11.3/13.5~75.9/91.1	Three-phase 400V class	1.5, 2.2, 3.7
Semflex-VM-1	1,800	270	F25	80	95	11.3/13.5~75.9/91.1		2.2, 3.7

※Inquire for mass

### Dimension drawings

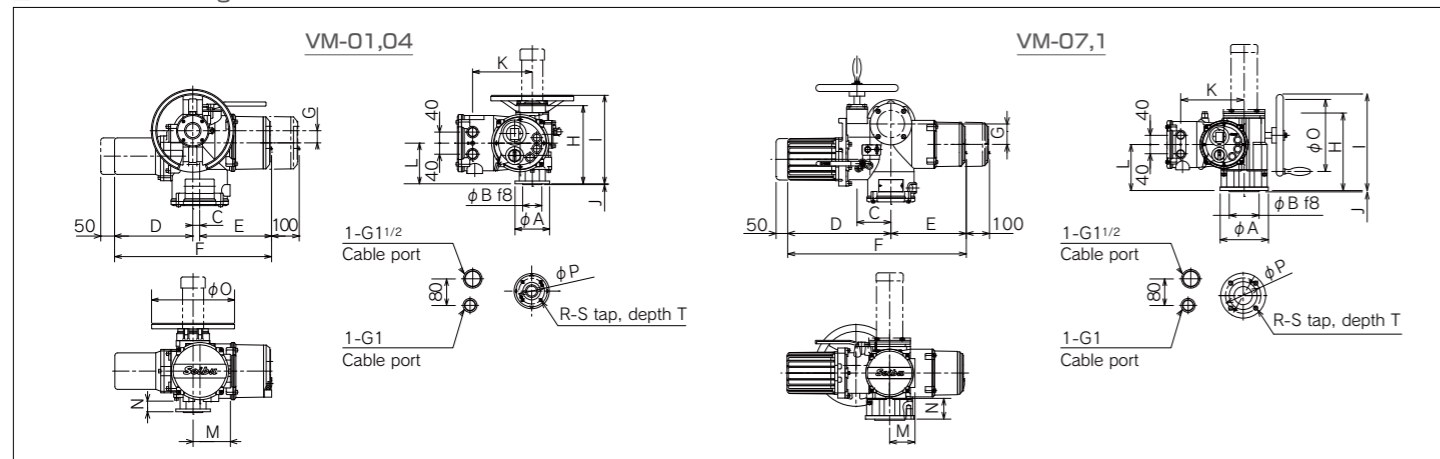

### Dimensions

Model	φA	φB	C	D	E	F	G	H	I	J	K	L	M	N	φO	φP	R	S	T
Semflex-VM-007	125	70	25	223	285	508	44	287.5	314	3	216	147	135	37	210	102	4	M10	30
Semflex-VM-01	125	70	25	283	285	568	44	287.5	320	3	216	147	135	37	300	102	4	M10	30
Semflex-VM-04	175	100	22	298	310	608	48	340.5	370	4	260	170	132	60	450	140	4	M16	38
Semflex-VM-07	210	130	146	445	325	770	88	335	417.5	5	276	200	110	90	314	165	4	M20	45
Semflex-VM-1	300	200	173	479	375	854	115	365	468	5	305	225	113	100	400	254	8	M16	43

※Please inquire for special installation or environmental requirements. (Vibration: Mechanism 1G max., electrical components exceeding 0.5G, noise, etc.)



## Butterfly valve implementation

Model: Semflex®-VM-01 / BRM-3F

- Motor operation**  
Via the actuator panel (standard equipment)
- Setting open/close limits and torque**  
Settable with pushbutton switches.
- Actuator status check**  
Position, torque alarm and other status information can be checked on the LCD.

### Operation panel



### List of models by pipe diameter (reference values)

Model	Applicable butterfly valves (mm)	Applicable gate valves (mm)
VM-007	100~300	50~100
VM-01	300~500	100~150
VM-04	600~900	200~500
VM-07	700~1000	300~700
VM-1	1000~1200	500~900

Note: We do not manufacture or sell valves.

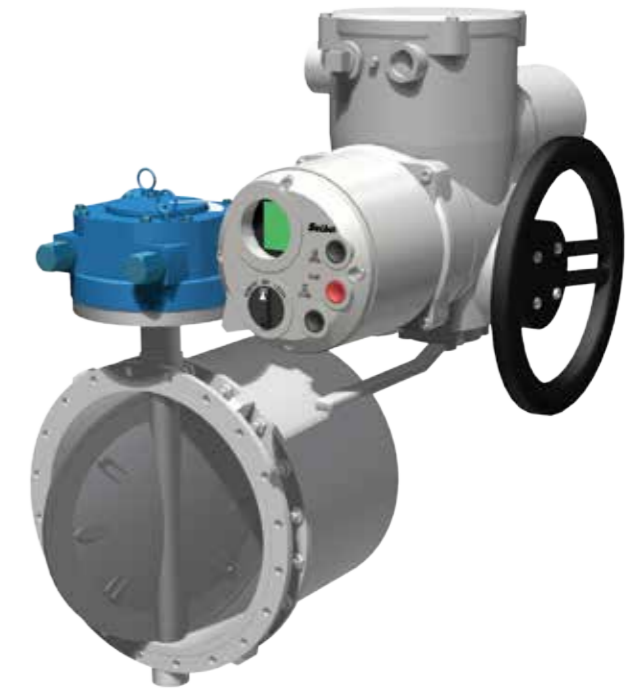

## Sample Semflex®-VM installation



### Description

Insulator wash system installed to prevent insulation degradation due to salt spray at insulator port. Semflex®-VM was used to open and close the valve for wash water.

### User requirements

The previous system had only on/off control, but the long pipe length resulted in abnormal pressure at close (water hammer). The customer required a slower valve closing speed to prevent water hammer issues.

### Solution proposal

The Semflex®-VM series with inverter control reduces valve open/close speed when the valve is almost closed, eliminating water hammer issues and delivering valve closure at nominal water pressure.

## Computerized actuators for small-diameter pipes

Small and lightweight with IP68-rated waterproofing and optional explosion-proof construction, perfect for installation in hazard areas.



### Features

- Small, lightweight design (about half the mass of our prior model).
- IP68-rated waterproofing and double sealing on terminals to minimize faults caused by liquid penetration.
- Valve operation possible immediately after supplying power.
- Supports wide range of operation (water-hammer prevention, valve purge, torque retry, etc.).
- On-board inverter (option) to adjust open/close speed.
- 2-wire PROFIBUS communication network (option) can be easily added.
- Valve interface complies with ISO5211.

### Applications

- Valves
- Gate valves
- Gates (flow control)

### Dimension drawings

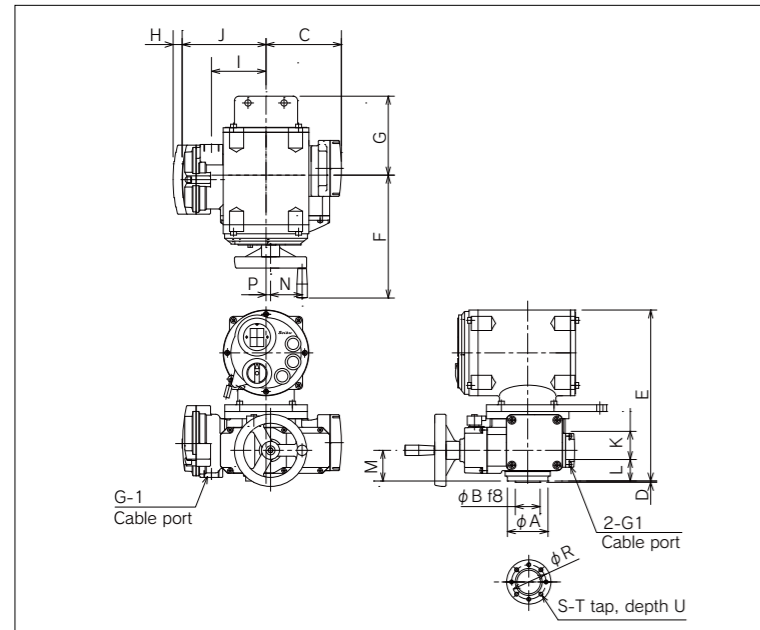

### Controller specifications

Function	Specification	Remarks
Main power supply	Three-phase AC 200V/400V class	
Control CPU	16-bit CPU with ADC and DAC, 16-MHz clock	
Position detection	Contactless potentiometer	
Torque detection	±5% precision	Worm motion sensing (contactless potentiometer)
LCD	Position (% open), fault icons, indicator, 3-character data	Displays with main power off
Basic operation	Open, stop, and close pushbuttons; Local/remote	
Adjustable open/close speed	Inverter (option)	
Position set	0%, 100%, and 4 intermediate user-defined points	User-definable within encoder count range
Torque set	User-adjustable between 30% and 100%	
Options	Inverter proportional control (stepless positioning), fieldbus support (PROFIBUS-DP), self-diagnosis	

### Specifications

Model	Max. output torque (Nm)	Flange size	Max. shaft dia. (mm)	Valve speed sec/90° (50/60 Hz)	Motor		Mass (kg)
					Power supply	Output W	
Semflex-VP-010	125	F07	28	9/7.5~18/15	Three-phase 200V class	40	25
Semflex-VP-020	250	F10	42	18/15~36/30		40	
Semflex-VP-060	600	F14	60	18/15~36/30	Three-phase 400V class	100	30
Semflex-VP-1	1,000			18/15~36/30		200	
Semflex-VP-2	2,000			36/30~72/60	200	52	

### Dimensions

Model	φA	φB	C	D	E	F	G	H	I	J	K	L	M	N	P	φR	S	T	U
Semflex-VP-010	90	55	167	3	379	281	113	20	121	186	56	64	68	R70	10	70	8	M8	15
Semflex-VP-020	125	70	191	3	396	325	130	20	136	202	60	60	65	R110	8	102	8	M10	15
Semflex-VP-060	175	100	268	4	462	363	191	20	174	240	60	111	141	R110	70	140	8	M16	15

\*Please inquire for special installation or environmental requirements. (Vibration:Mechanism 1G max.,electrical components exceeding 0.5G, noise,etc).



## Butterfly valve implementation

Model:Semflex®-VP-010

1. Motor operation  
Via the actuator panel (standard equipment)
2. Setting open/close limits and torque  
Settable with pushbutton switches.
3. Actuator status check  
Position, torque alarm and other status information can be checked on the LCD.

### Operation panel



### List of models by pipe diameter (reference values)

Model	Applicable butterfly valves (mm)
VP-010	50~100
VP-020	50~150
VP-060	150~300
VP-1	200~350
VP-2	250~400



Note:We do not manufacture or sell valves.

## Sample Semflex®-VP installation



### Description

A midsize coastal petroleum tanker installed power freight handling and ballast piping valves. As the trial vessel for the national Super Eco-Ship (SES) research project, it completed national evaluations and is now in commercial service.

### User requirements

Hydraulic actuators have been commonly used in hazard areas of petroleum and gas tankers to prevent explosions, but the requirement was for electric valve actuators to reduce the needed hydraulic machinery and marine pollution. Construction for the control system and wiring also needed to be reduced to minimize cost.

### Solution proposal

The Semflex®-VP and VM series of electric valve actuators were linked via the PROFIBUS field bus, significantly reducing control panel wiring. In addition, the system supports valve operational data monitoring and valve actuator preventive maintenance.





## Package software

Connect up to 125 power valve actuators

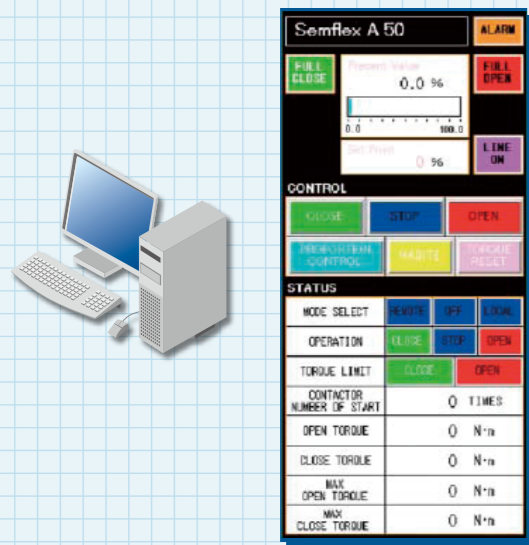

- Simpler operation
- Easier maintenance
- Lower cost

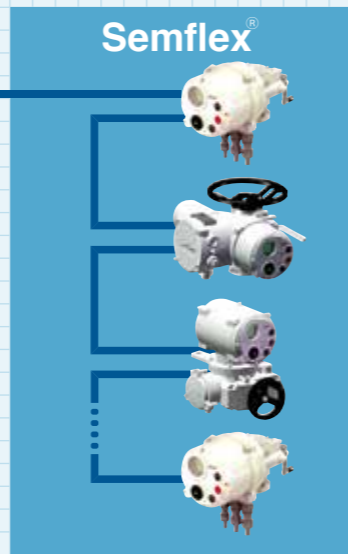

Monitor many data items (torque, motor current, number of operations, etc.) to prolong service life of actuators and valves by status control, self-diagnosis, and preventative maintenance (failure prediction).

### General PROFIBUS-SP communication specifications

Communication protocol	PROFIBUS-DP	
Interface	RS-485	
Baud rate / range	Baud rate (kbit/s)	Cable length (without repeater)
	9.6	1200m
	19.2	1200m
	93.75	1200m
	187.5	1000m
	500.0	400m
Wiring	Twist pair cable	
	DP Master class 1 (PLC, PC, etc.)	
	DP Master class 2 (programming configuration tool)	
Station types	DP Slave (other slave systems)	
	32 stations without repeater	
Connected stations	With repeater expandable up to 125	
	Communication settings	Data: 8 bit
Encoding	Parity: Odd	
	Stop bit: 1	
	Non Return to Zero (NRZ)	

### PROFIBUS-DP·Semflex interface

Electronic controls	Integral controls Seibu Semiflex series
Baud rate detection	Automatic
Control signals	OPEN
	STOP
	CLOSE
	Proportional control [Option]
	Limit switch OPEN/CLOSE
Feedback signals	Torque switch OPEN/CLOSE
	Opening/Closing signals
	Position REMOTE
	Valve position [Option]
	Self diagnosis data [Option]
Fault signals	1.Motor protection tripped
	2.Torque abnormal
	3.Other

## Application examples

### Steelmaking plant

#### Fast response, lower cost

The power valve actuator offers fast control response for accurate valve operation. Because it does not use conventional I/O contact control, installation wiring and labor costs are also reduced.

#### Simplified maintenance

Electronic sensors slash the component count, for a smaller, lighter, simpler construction, which simplifies maintenance and provides significant reductions in required personnel and man-hours.



### Plant machinery

#### PROFIBUS-DB communication system

Semflex series products can be automatically controlled via PROFIBUS communication, contributing to unmanned operation, and improving operational safety and transport quality.

#### Self-diagnosis function

Various data items (torque, motor current, number of operations, etc.) can be monitored at high speed via the communication path for simple actuator and valve status management. Ideal for preventing trouble and implementing planned maintenance.



Intelligent system merits

Digital communication between plant production equipment and the controlling PC enables a variety of control operations, while providing a host of advantages including improved communication accuracy and redundancy, and reduced wiring cost.

### Reduced wiring cost

Conventional wiring  
Requires a control cable (CVV: 12C) and a transmitter cable (CVVS: 3C) (reference)

Communication is possible with the PROFIBUS cable alone

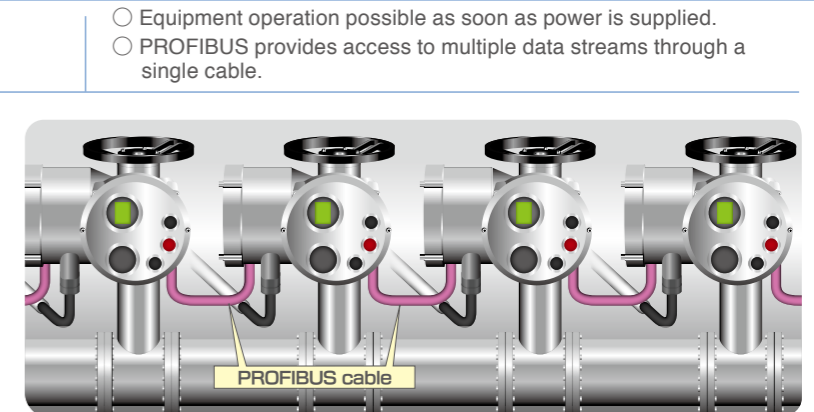

- Equipment operation possible as soon as power is supplied.
- PROFIBUS provides access to multiple data streams through a single cable.

### Fewer personnel needed for plant management

- Datacom-enabled self-diagnosis facilitates valve maintenance.
- Simple remote actuator operation to commands from central computer.

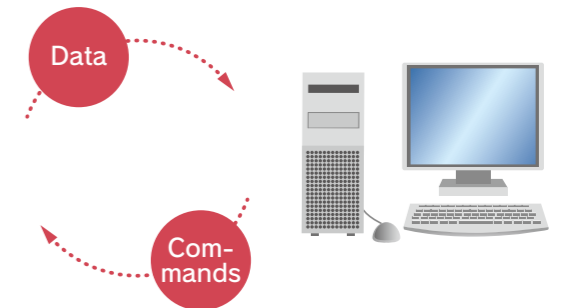
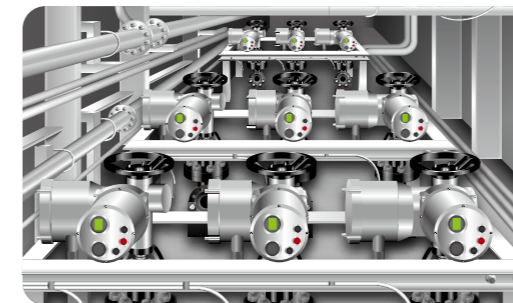

### Diverse control and operation

- Quick and easy support for valve purge, torque retry, variable speed (option) and more.

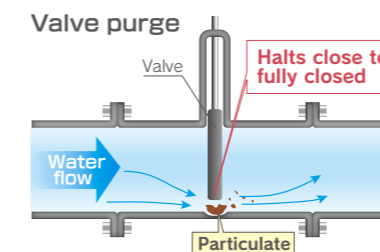

Valve halts close to fully closed, using flow to remove particles.

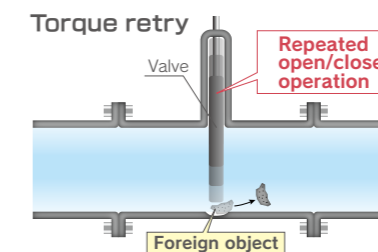

After over-torque detection, open/close is repeated several times.

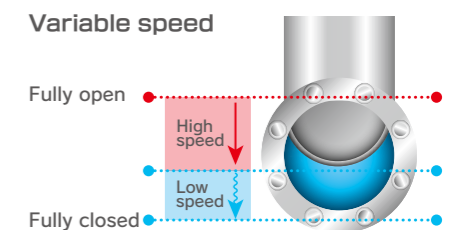

Speed is varied, with high-speed operation from fully open almost to fully closed, and then low-speed operation until fully closed.

### Self-diagnosis

- Various data items (torque, motor current, number of operations, etc.) can be monitored at high speed, prolonging actuator and valve service life and facilitating status management.

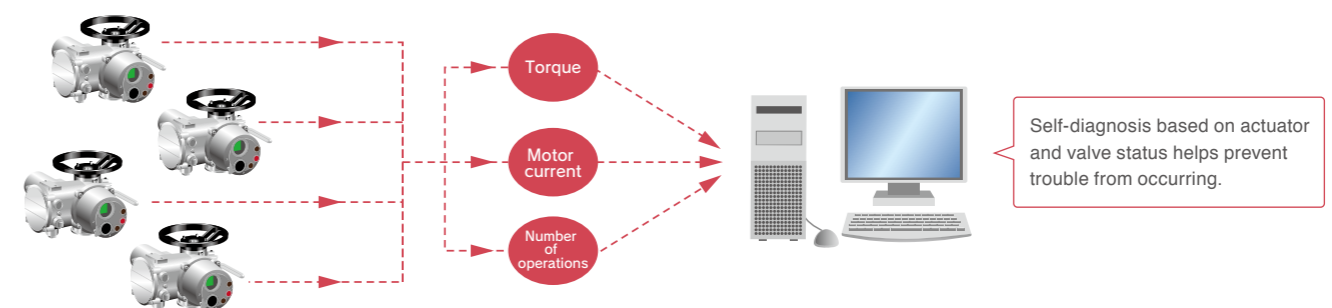

Self-diagnosis based on actuator and valve status helps prevent trouble from occurring.

Realize automatic optimization of control using AI functionality!

## AI Valve Control

### Build a smart factory based on distributed control

- Route sensor signals directly into valve controllers.
- Judge sensor signals inside valve controllers and open and close valves accordingly (AI-PID control).
- Realize redundant operation with inter-device communication between main valve controllers and sub valve controllers.

Application fields: Chemical plants, pharmaceutical plants, shipping

Note: Specifications are subject to change without notice.

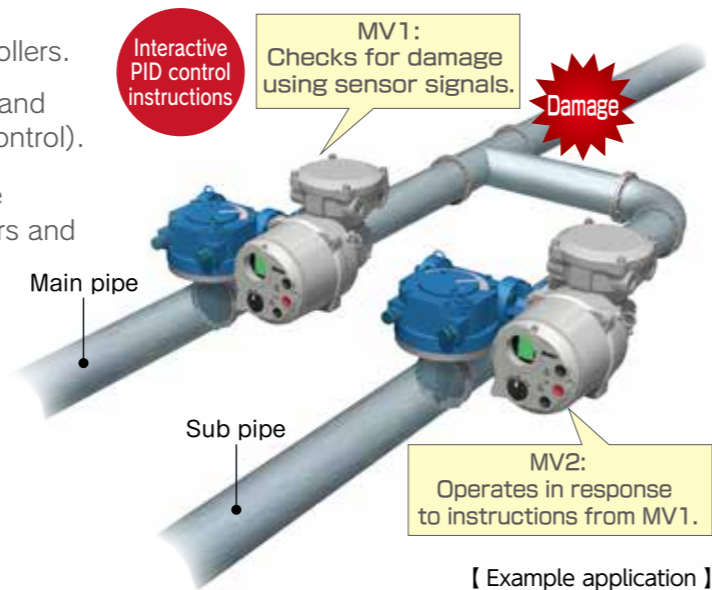

Improving safety and operating efficiency in plant equipment

## Remote Control Specification (V-CON)

Protect actuator electronics from harsh installation environments  
Boost work efficiency in site operations

Example sites

- High-temperature areas
- Pipes with a high level of vibration
- Pipes in high locations
- Underground pits

Application fields: Steel plants, power plants, cement plants

※Please contact Seibu in advance concerning operating conditions.  
※Can also be connected to SRJ.  
Note: Specifications are subject to change without notice.

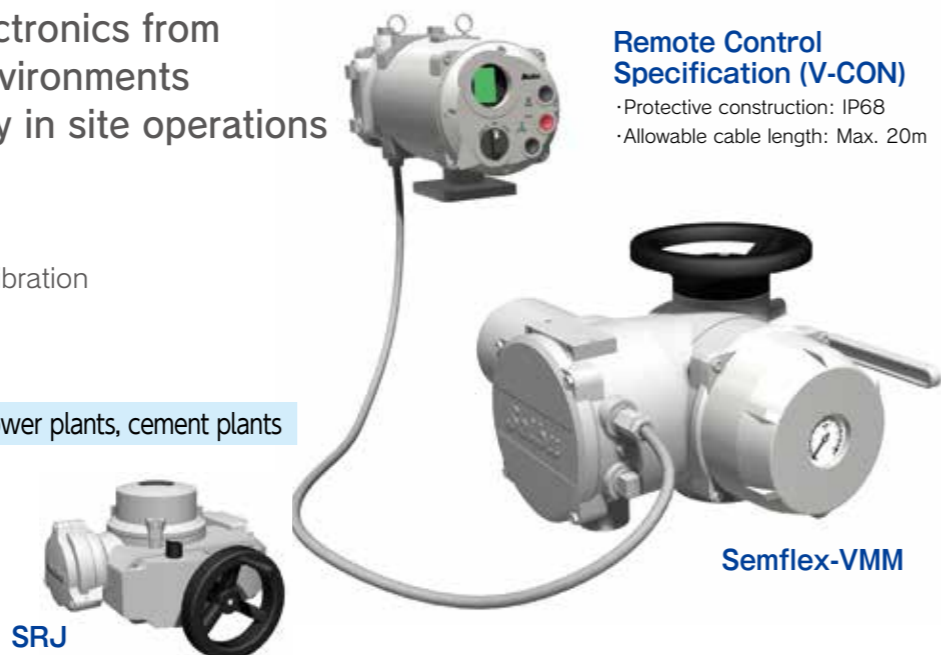

Prepare for power outages during natural disasters!

## SBS [Seibu Backup System] Battery Backup System

### Ensure equipment safety in the event of a blackout (large-scale power outage)

#### 【Proposed SBS applications】

- Realize compact protection of key equipment at small plants using actuators that operate on battery power in the event of an outage. (Reducing cost impact and running costs)



SBS BOX (model with external drive unit)

#### Compatible models:

SSemflex VM-01, 04 (max. 550Nm)  
Semflex VP-010, 020, 060, 1, 2 (max. 2,000Nm)

#### Compatible power supplies:

Single-phase 100/200V 50/60Hz

※Please contact Seibu for more information about other specifications, for example explosion-proof models.

- SBS can also be used as a simplified version of the large UPS systems used at large plants (by stripping out unnecessarily robust specifications).

Application fields: Emergency shutoff valves, chemical plants, geothermal plants, pharmaceutical plants

Note: Specifications are subject to change without notice.

#### 【SBS overview】

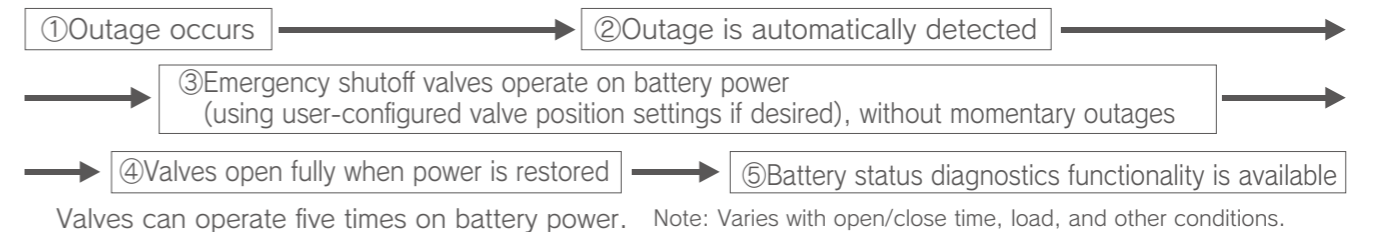

#### 【SBS block diagram】

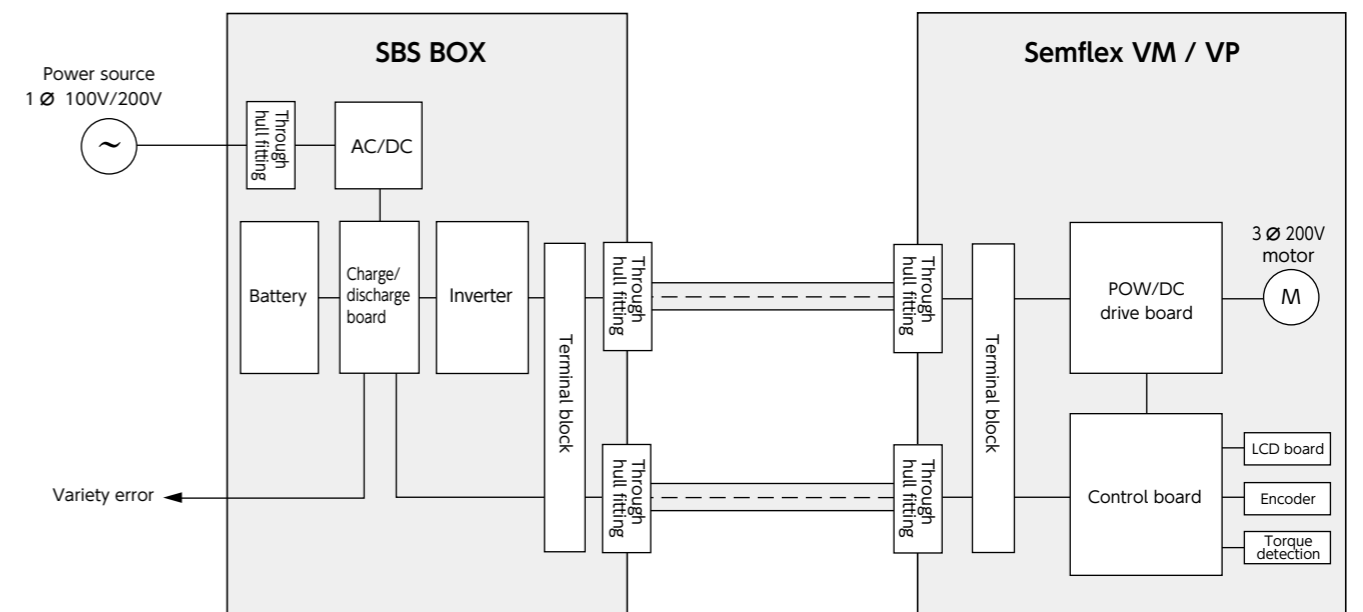



# Field-Proven Safety, Reliability, and Durability: Seibu Valve Actuators Command the Top Share of the Japan Market

## Semflex®-VMM series



Semflex-VMM-007

<b>Semflex-VMM-007</b>	Allowable torque: 70Nm/Allowable thrust: 70kN Sleeve speed min <sup>-1</sup> (50/60Hz) 11.3/13.5~75.9/91.1
<b>Semflex-VMM-01</b>	Allowable torque: 150Nm/Allowable thrust: 70kN Sleeve speed min <sup>-1</sup> (50/60Hz) 11.3/13.5~75.9/91.1
<b>Semflex-VMM-04</b>	Allowable torque: 550Nm/Allowable thrust: 130kN Sleeve speed min <sup>-1</sup> (50/60Hz) 11.3/13.5~75.9/91.1
<b>Semflex-VMM-07</b>	Allowable torque: 850Nm/Allowable thrust: 160kN Sleeve speed min <sup>-1</sup> (50/60Hz) 11.3/13.5~75.9/91.1
<b>Semflex-VMM-1</b>	Allowable torque: 1800Nm/Allowable thrust: 270kN Sleeve speed min <sup>-1</sup> (50/60Hz) 11.3/13.5~75.9/91.1

※Sleeve speeds are reference only.

IP 55	IP 67	IP 68		
Limit switch	Torque switch	Interlock	Explosion-proof	Synch transmitter
Transmitter DC4~20mA output	Transmitter DC4~20mA I/O	Manual recovery	Automatic recovery	

■ = Standard specification □ = Not available ▒ = Option  
※Detail specifications available on request.

## LTRH/LTRM/LTKD/LTMD/LTKB series



LTRH-01



LTKD-01



LTKD-5



LTKB (ballscrew specification)

<b>LTRH-01</b> <b>LTRM-01</b>	Allowable torque: 120Nm/Allowable thrust: 38kN Sleeve speed min <sup>-1</sup> (50/60Hz) 10.9/13.0~35.6/42.8
<b>LTKD-01</b> <b>LTMD-01</b>	Allowable torque: 250Nm/Allowable thrust: 45kN Sleeve speed min <sup>-1</sup> (50/60Hz) 10.6/12.6~71.3/85.5
<b>LTKD-02</b> <b>LTMD-02</b>	Allowable torque: 450Nm/Allowable thrust: 65kN Sleeve speed min <sup>-1</sup> (50/60Hz) 10.5/12.7~66.0/79.2
<b>LTKD-05</b> <b>LTMD-05</b>	Allowable torque: 850Nm/Allowable thrust: 105kN Sleeve speed min <sup>-1</sup> (50/60Hz) 14.8/17.8~71.3/85.5

※Sleeve speeds are reference only.

IP 55	IP 67	IP 68		
Limit switch	Torque switch	Interlock	Explosion-proof	Synch transmitter
Transmitter DC4~20mA output	Transmitter DC4~20mA I/O	Manual recovery	Automatic recovery	Position data

■ = Standard specification □ = Not available ▒ = Option  
※Detail specifications available on request.

<b>LTKD-1</b> <b>LTMD-1</b>	Allowable torque: 1,750Nm/Allowable thrust: 200kN Sleeve speed min <sup>-1</sup> (50/60Hz) 9.3/11.2~66.0/79.2
<b>LTKD-3</b> <b>LTMD-3</b>	Allowable torque: 4,000Nm/Allowable thrust: 320kN Sleeve speed min <sup>-1</sup> (50/60Hz) 8.0/9.6~64.5/77.4
<b>LTKD-5</b> <b>LTMD-5</b>	Allowable torque: 6,500Nm/Allowable thrust: 500kN Sleeve speed min <sup>-1</sup> (50/60Hz) 10.7/12.9~61.2/73.4
<b>LTKD-10B</b> <b>LTMD-10B</b>	Allowable torque: 12,000Nm/Allowable thrust: 1,100kN Sleeve speed min <sup>-1</sup> (50/60Hz) 10.6/12.8~63.1/75.7

※Sleeve speeds are reference only.

IP 55	IP 67	IP 68		
Limit switch	Torque switch	Interlock	Explosion-proof	Synch transmitter
Transmitter DC4~20mA output	Transmitter DC4~20mA I/O	Manual recovery	Automatic recovery	Position data

■ = Standard specification □ = Not available ▒ = Option  
※Detail specifications available on request.

## SRH series

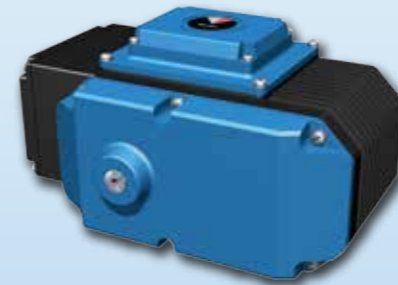

SRH-060

<b>SRH-007</b>	Allowable torque: 70 Nm Open/close time sec/90° (50/60Hz) 12/10-24/20
<b>SRH-020</b>	Allowable torque: 200 Nm Open/close time sec/90° (50/60Hz) 12/10-24/20
<b>SRH-060</b>	Allowable torque: 600 Nm Open/close time sec/90° (50/60Hz) 18/15-36/30

IP 55	IP 67	IP 68		
Limit switch	Torque switch	Interlock	Explosion-proof	Synch transmitter
Transmitter DC4~20mA output	Transmitter DC4~20mA I/O	Manual recovery	Automatic recovery	Position data

■ = Standard specification □ = Not available ▒ = Option  
※Detail specifications available on request.

## SRJ series

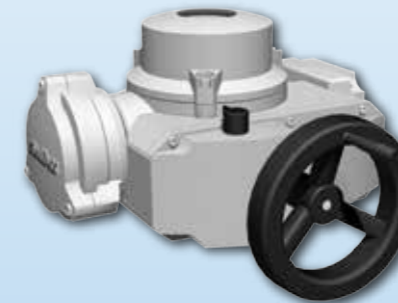

SRJ-010

<b>SRJ-010</b>	Allowable torque: 125 Nm Open/close time sec/90° (50/60Hz) 9/7.5-18/15
<b>SRJ-020</b>	Allowable torque: 250 Nm Open/close time sec/90° (50/60Hz) 18/15-36/30
<b>SRJ-060</b>	Allowable torque: 600 Nm Open/close time sec/90° (50/60Hz) 18/15-36/30
<b>SRJ-1</b>	Allowable torque: 1,000 Nm Open/close time sec/90° (50/60Hz) 18/15-36/30
<b>SRJ-2</b>	Allowable torque: 2,000 Nm Open/close time sec/90° (50/60Hz) 36/30-72/60

IP 55	IP 67	IP 68		
Limit switch	Torque switch	Interlock	Explosion-proof	Synch transmitter
Transmitter DC4~20mA output	Transmitter DC4~20mA I/O	Manual recovery	Automatic recovery	Position data

■ = Standard specification □ = Not available ▒ = Option  
※Detail specifications available on request.

## BRM series

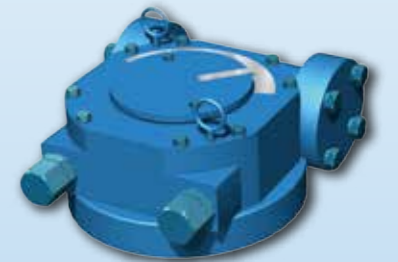

BRM-3-H

<b>BRM-1</b>	Allowable torque: 1,000 Nm	<b>BRM-10</b>	Allowable torque: 10,000Nm
<b>BRM-2</b>	Allowable torque: 2,000 Nm	<b>BRM-18</b>	Allowable torque: 18,000 Nm
<b>BRM-3</b>	Allowable torque: 3,000 Nm	<b>BRM-40</b>	Allowable torque: 40,000 Nm
<b>BRM-4</b>	Allowable torque: 4,000 Nm	<b>BRM-80</b>	Allowable torque: 80,000 Nm
<b>BRM-5</b>	Allowable torque: 5,000 Nm	<b>BRM-150</b>	Allowable torque: 150,000 Nm

IP 55	IP 67	IP 68		
Limit switch	Torque switch	Interlock	Explosion-proof	Synch transmitter
Transmitter DC4~20mA output	Transmitter DC4~20mA I/O	Manual recovery	Automatic recovery	Position data

■ = Standard specification □ = Not available ▒ = Option  
※Detail specifications available on request.

## Mechanical actuators featuring the basic structure of the VM series

This series of actuators incorporates proven technology (mechanical limit and torque switches as well as valve position meters) with standard IP68-rated waterproofing and includes integral models.



Semflex-VMM-007

### Features

Small, lightweight design (about half the mass of our prior model).  
 IP68-rated waterproofing\*1 and double sealing on terminals to minimize faults caused by liquid penetration.  
 Integral and proportional control (DC 4mA to 20mA input/output) models are available.  
 Valve interface complies with ISO5211.

### Applications

- Valves
- Gate valves
- Gates (flow control)



Semflex-VMM-07

### List of models by pipe diameter (reference values)

Model	Applicable butterfly valves (mm)	Applicable gate valves (mm)
VMM-007	100~300	50~100
VMM-01	300~500	100~150
VMM-04	600~900	200~500
VMM-07	700~1000	300~700
VMM-1	1000~1200	500~900

### Specifications

Model	Max. output torque (Nm)	Max. thrust (kN)	Flange size	Max. shaft dia. (mm)		Output speed min <sup>1</sup> (50/60Hz)	Motor	
				Rod	Screw		Power supply	Output kW
Semflex-VMM-007	70	70	F10	34	40	11.3/13.5~75.9/91.1	Three-phase 200V class	0.1, 0.2
Semflex-VMM-01	150	70	F10	34	40	11.3/13.5~75.9/91.1	Three-phase 200V class	0.2, 0.4, 0.75
Semflex-VMM-04	550	130	F14	50	58	11.3/13.5~75.9/91.1	Three-phase 400V class	0.75, 1.5, 2.2
Semflex-VMM-07	850	160	F16	60	72	11.3/13.5~75.9/91.1	Three-phase 400V class	1.5, 2.2, 3.7
Semflex-VMM-1	1,800	270	F25	80	95	11.3/13.5~75.9/91.1	Three-phase 400V class	2.2, 3.7

\*Inquire for mass.

### VMM-007, 01, 04

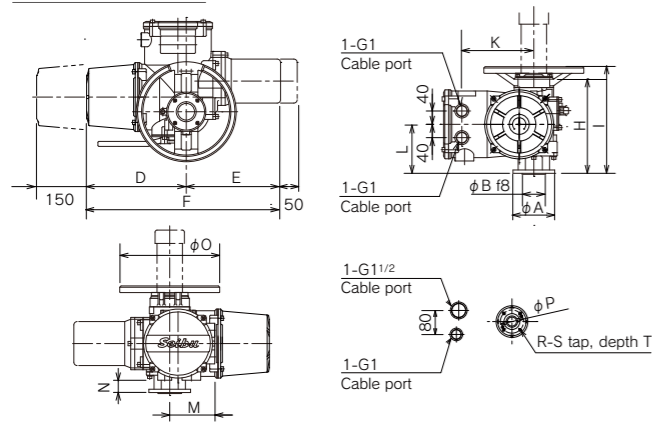

### VMM-07, 1

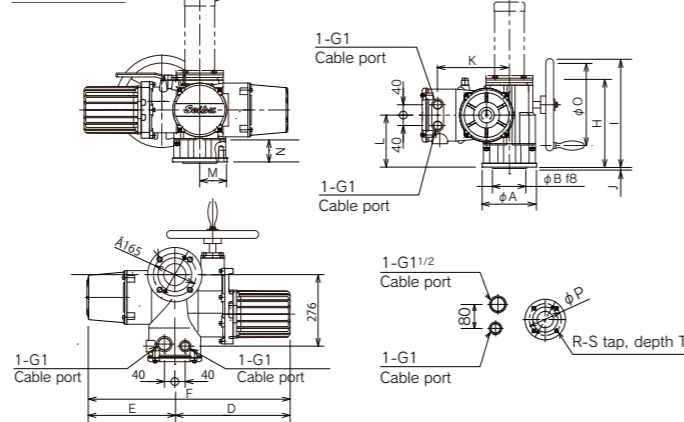

### Dimension drawings

Model	φA	φB	C	D	E	F	G	H	I	J	K	L	M	N	φO	φP	R	S	T
Semflex-VMM-007	125	70	25	223	255	478	44	287.5	314	3	216	147	135	37	210	102	4	M10	30
Semflex-VMM-01	125	70	25	283	285	568	44	287.5	320	3	216	147	135	37	300	102	4	M10	30
Semflex-VMM-04	175	100	22	298	310	608	48	340.5	370	4	260	170	132	60	450	140	4	M16	38
Semflex-VMM-07	210	130	146	445	325	770	88	335	417.5	5	276	200	110	90	314	165	4	M20	45
Semflex-VMM-1	300	200	173	479	375	854	115	365	468	5	305	225	113	100	400	254	8	M16	43

\*Please inquire for special installation or environmental requirements. (Vibration: Mechanism 1G max., electrical components exceeding 0.5G, noise, etc)

\*1. Equivalent to submersion for 72 hours in 8m of water (not designed for submersible use).

## Integral type (VMM-Z)

### Operation panel (optional specifications)

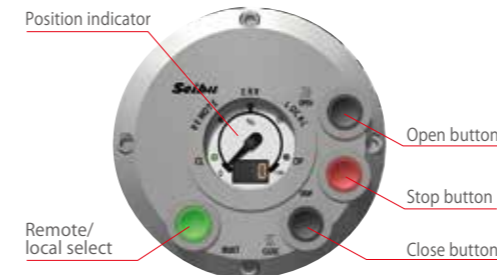

### Controller specifications

Function	Specification
Main power supply	Three-phase AC 200V / 400V class
Control CPU	16-bit CPU with ADC and DAC, 32-MHz clock
LED indicators	Full open, full close, remote / local indicators (% open). 3-character error display
Basic operation	Open, stop, and close pushbuttons; Local / remote
Option	Proportional control Fieldbus support (PROFIBUS-DP) Modbus support (Modbus-RTU)



## Semflex®-VMM installation



### Description

Customers have chosen high-end valve actuators with standard IP68-rated waterproofing for installation in applications including sedimentation basins and filter basins at water and sewage treatment plants and cooling equipment at steel

### User requirements

In the past, customers used valve actuators with standard IP55-rated waterproofing. Today, they demand valve actuators with even greater water resistance, watertightness, and waterproofness.

### Solution proposal

Seibu proposed the VMM series of compact valve actuators, which features standard IP68 protective construction for excellent water resistance and waterproofness. By choosing valve actuators with excellent water resistance, customers can realize simplified maintenance and reduced running costs.



Features

- Manual and automatic recovery
- Safety mechanisms: limit switch, torque switch, interlock (LTRH only)
- Compact and lightweight for easy installation into tight spaces



Dimension drawings

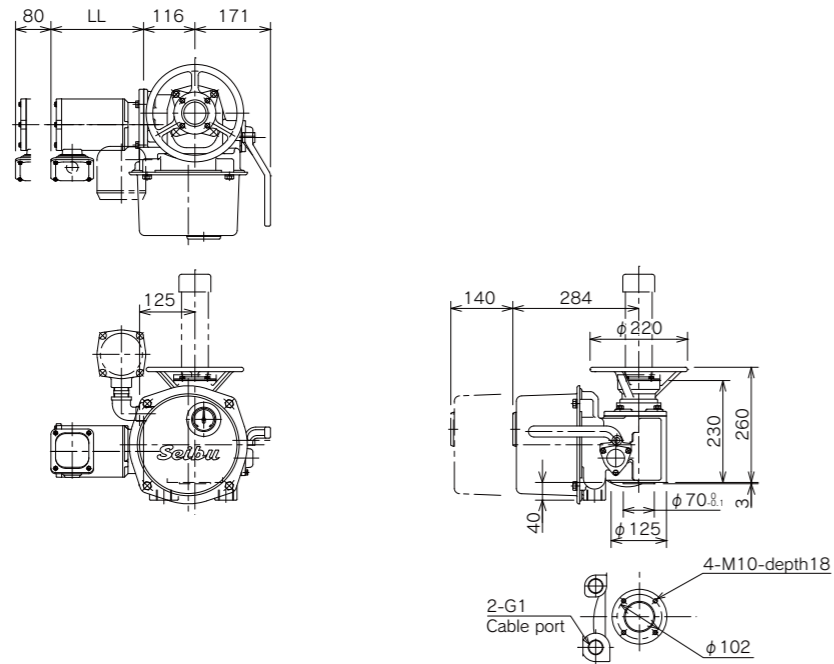

Specifications

Model	Allowable torque (Nm)	Allowable thrust (kN)	Allowable valve stem dia. (mm)		Sleeve speed min <sup>-1</sup> (50/60 Hz)	Motor	
			Rising stem	Non-rising stem		Power supply	Output kW
LTRH-01	120	38	28	30	10.9/13.1~35.6/42.8	Three-phase 200V class	
LTRM-01						Three-phase 400V class (Please inquire for single-phase specifications)	
Motor output (kW)		0.1		0.2		0.4	
KD/LL	Without brake	G3/4 / 209		G3/4 / 209		G3/4 / 202	
	With brake	G3/4 / 195		G3/4 / 282 (259)		G3/4 / 285 (263)	
Motor removal space X		80		80		80	

※Please inquire for special installation or environmental requirements. (Vibration:Mechanism 1G max.,electrical components exceeding 0.5G, noise,etc).

Features

- Manual and automatic recovery
- Safety mechanisms: limit switch, torque switch, interlock (LTKD only)
- Uses motor appropriate for valve. Improved safety with independent wiring using dedicated terminal box.
- One-touch auto/manual select
- Available in submersible and explosion-proof specifications



Dimension drawings for LTKD-01/02 and LTMD-01/02

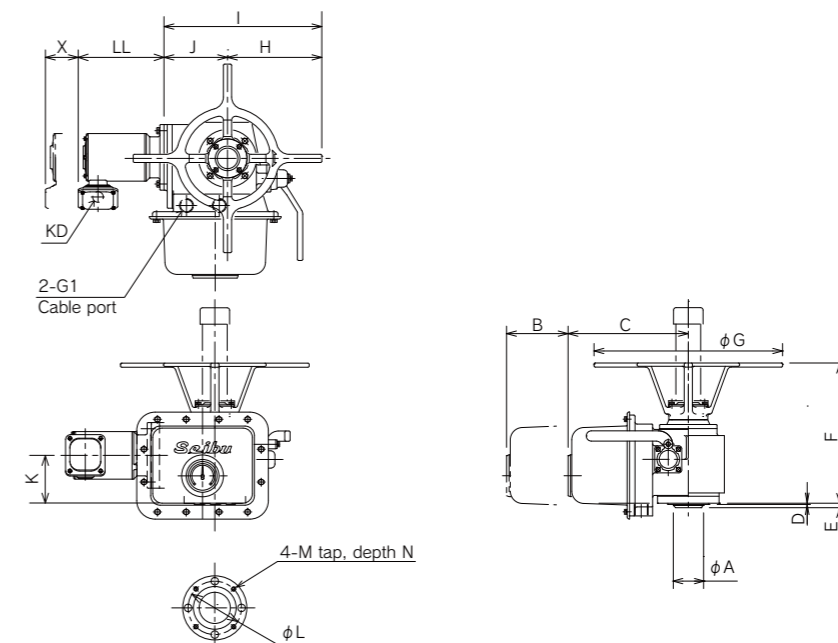

Specifications for LTKD-01/02 and LTMD-01/02

Model	Allowable torque (Nm)	Allowable thrust (kN)	Allowable valve stem dia. (mm)		Sleeve speed min <sup>-1</sup> (50/60 Hz)	Motor	
			Rising stem	Non-rising stem		Power supply	Output kW
LTKD-01/LTMD-01	250	45	28	30	10.6/12.6~71.3/85.5	Three-phase 200V class Three-phase 400V class (Please inquire for single-phase or DC specifications)	
LTKD-02/LTMD-02	450	65	40	42	10.5/12.7~66.0/79.2	0.2,0.4,0.75 0.4,0.75,1.5	

※Inquire for mass.

Dimensions for LTKD-01/02 and LTMD-01/02

Model	φA	B	C	D	E	F	φG	H	I	J	K	φL	M	N
LTKD-01/LTMD-01	73	150	293	3	11	342	460	230	385	155	117	125	M10	17
LTKD-02/LTMD-02	88	160	327	4	12	377	460	230	385	155	142	160	M12	22
Motor output (kW)		0.2			0.4			0.75			1.5			
KD/LL	Without brake	G3/4 / 209			G3/4 / 202			G3/4 / 215			G3/4 / 243			
	With brake	G3/4 / 282 (259)			G3/4 / 285 (263)			G3/4 / 304			G3/4 / 334			
Motor removal space X		80			80			80			80			

※Please inquire for special installation or environmental requirements. (Vibration:Mechanism 1G max.,electrical components exceeding 0.5G, noise,etc).



Features

- Manual recovery
- Safety mechanisms: limit switch, torque switch, interlock
- Uses motor appropriate for valve. Improved safety with independent wiring using dedicated terminal box.
- Standard safety equipment prevents damage to valve and gate even if excess force applied in manual operation.
- Available in submersible and explosion-proof specifications.

Dimension drawings

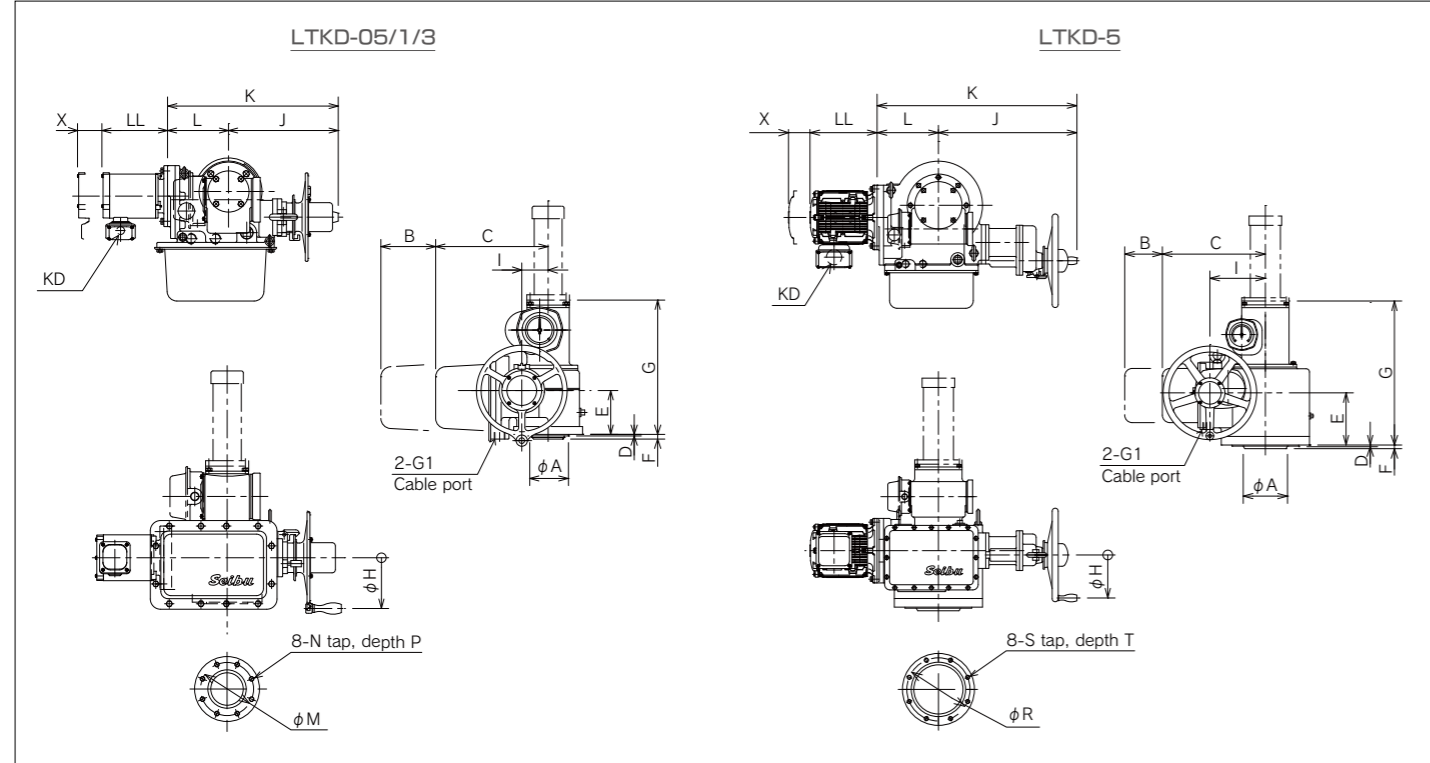

Specifications

Model	Allowable torque (Nm)	Allowable thrust (kN)	Allowable valve stem dia. (mm)		Sleeve speed min <sup>-1</sup> (50/60 Hz)	Motor	
			Rising stem	Non-rising stem		Power supply	Output kW
LTKD-05	850	105	50	52	14.8/17.8~71.3/85.5	Three-phase 200V class	0.4, 0.75, 1.5, 2.2, 3.7
LTKD-1	1,750	200	62	70	9.3/11.2~66.0/79.2	Three-phase 400V class	1.5, 2.2, 3.7, 5.5
LTKD-3	4,000	320	80	90	8.0/9.6~64.5/77.4	(Please inquire for single-phase or DC specifications)	3.7, 5.5, 7.5, 11
LTKD-5	6,500	500	100	115	10.7/12.9~61.2/73.4		5.5, 7.5, 11, 15

※Inquire for mass.

Dimensions

Model	φA	B	C	D	E	F	G	φH	I	J	K	L	φM	N	P	φR	S	T
LTKD-05	103	175	359	5	140	15	429	160	84	360	575	200	180	M16	25	-	-	-
LTKD-1	132	175	400	5	175	17	490	160	110	425	685	260	250	M16	25	-	-	-
LTKD-3	168	170	411	5	200	20	545	200	151	470	740	270	300	M20	30	-	-	-
LTKD-5	206	175	479	5	243	18	665	200	258	644	929	285	-	-	-	360	M24	40

Motor output (kW)		0.4	0.75	1.5	2.2	3.7	5.5	7.5	11	15
KD/LL	Without brake	G3/4 / 202	G3/4 / 215	G3/4 / 243	G3/4 / 264	G3/4 / 278	G1 / 312	G1 / 350	G1 / 435	G1 / 435
	With brake	G3/4 / 285	G3/4 / 304	G3/4 / 334	G3/4 / 358	G3/4 / 392	G1 / 424	G1 / 467	G1 / 594	G1 / 594
	Without Loosen equipment in ( )	(263)								
Motor removal space X		80	80	80	80	100	100	100	150	150

※Please inquire for special installation or environmental requirements. (Vibration: Mechanism 1G max., electrical components exceeding 0.5G, noise, etc.)



Features

- Manual recovery
- Safety mechanisms: limit switch, torque switch, etc.
- Uses motor appropriate for valve. Improved safety with independent wiring using dedicated terminal box.
- Standard safety equipment prevents damage to valve and gate even if excess force applied in manual operation.
- Available in submersible and explosion-proof specifications.
- Note: Model also available with mechanical interlocks (LTMDG)

Dimension drawings

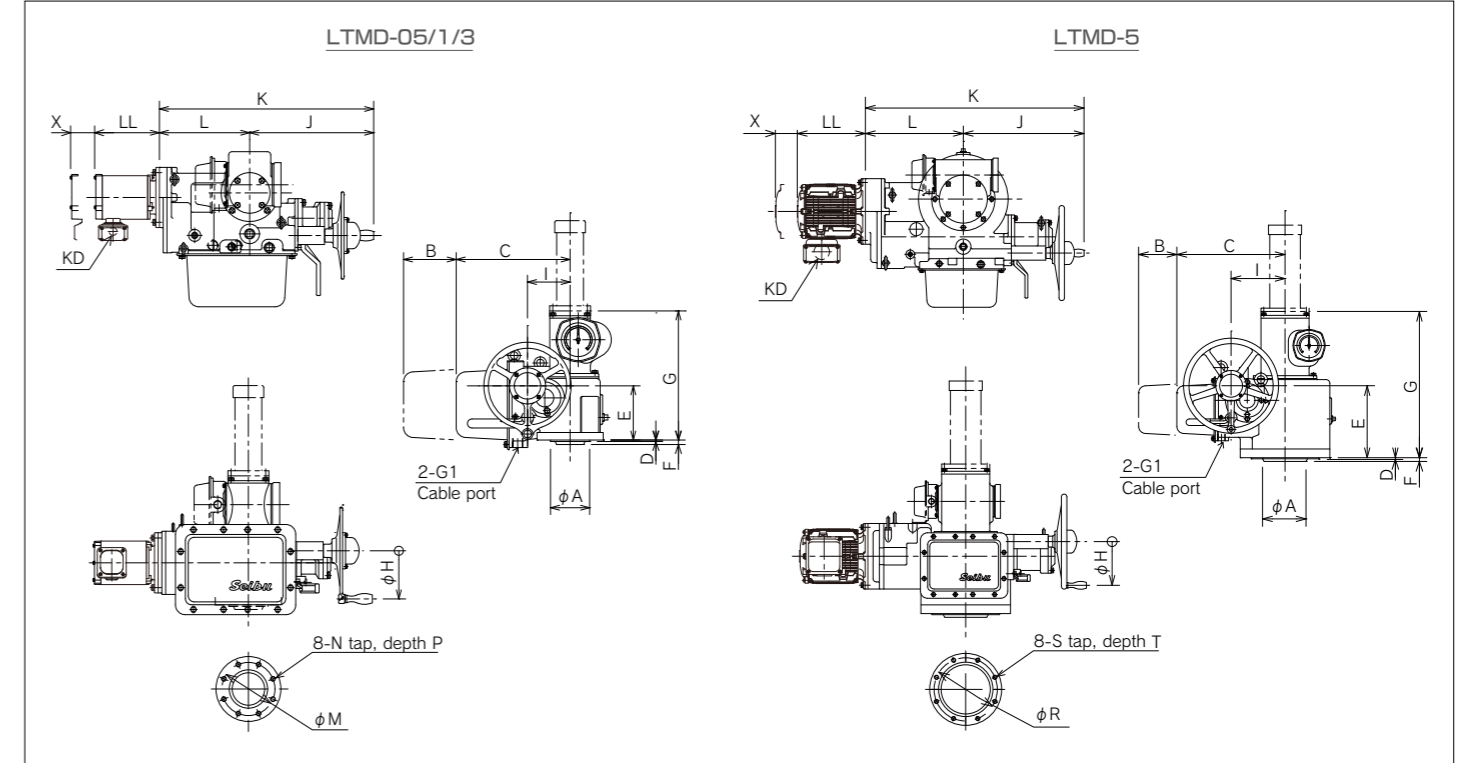

Specifications

Model	Allowable torque (Nm)	Allowable thrust (kN)	Allowable valve stem dia. (mm)		Sleeve speed min <sup>-1</sup> (50/60 Hz)	Motor	
			Rising stem	Non-rising stem		Power supply	Output kW
LTMD-05	850	105	50	52	14.8/17.8~71.3/85.5	Three-phase 200V class	0.4, 0.75, 1.5, 2.2, 3.7
LTMD-1	1,750	200	62	70	9.3/11.2~66.0/79.2	Three-phase 400V class	1.5, 2.2, 3.7, 5.5
LTMD-3	4,000	320	80	90	8.0/9.6~64.5/77.4	(Please inquire for single-phase or DC specifications)	3.7, 5.5, 7.5, 11
LTMD-5	6,500	500	100	115	10.7/12.9~61.2/73.4		5.5, 7.5, 11, 15

※Inquire for mass.

Dimensions

Model	φA	B	C	D	E	F	G	φH	I	J	K	L	φM	N	P	φR	S	T
LTMD-05	103	175	360	5	140	16	429	160	84	375	575	200	180	M16	25	-	-	-
LTMD-1	132	175	400	5	175	17	490	160	110	425	685	260	250	M16	25	-	-	-
LTMD-3	168	170	411	5	200	20	545	200	151	470	740	270	300	M20	30	-	-	-
LTMD-5	206	175	477	5	242.5	18	665	200	258	645	929	285	-	-	-	360	M24	40

Motor output (kW)		0.4	0.75	1.5	2.2	3.7	5.5	7.5	11	15
KD/LL	Without brake	G3/4 / 202	G3/4 / 215	G3/4 / 243	G3/4 / 264	G3/4 / 278	G1 / 312	G1 / 350	G1 / 435	G1 / 435
	With brake	G3/4 / 285	G3/4 / 304	G3/4 / 334	G3/4 / 358	G3/4 / 392	G1 / 424	G1 / 467	G1 / 594	G1 / 594
	Without Loosen equipment in ( )	(263)								
Motor removal space X		80	80	80	80	100	100	100	150	150

※Please inquire for special installation or environmental requirements. (Vibration: Mechanism 1G max., electrical components exceeding 0.5G, noise, etc.)



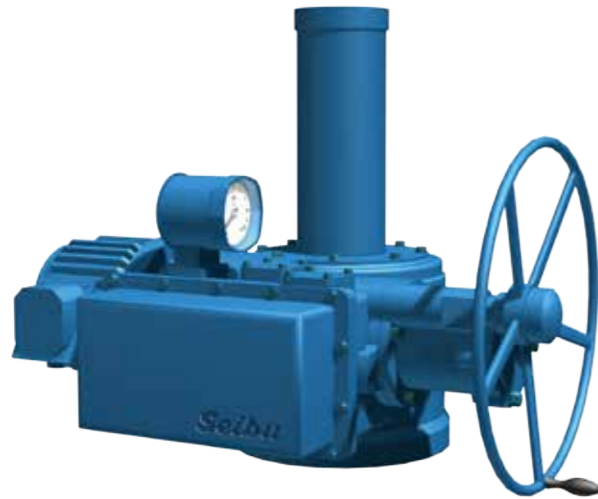

Features

- Manual recovery
- Safety mechanisms: limit switch, torque switch, interlock (LTKD only)
- Uses motor appropriate for valve. Improved safety with independent wiring using dedicated terminal box.
- Standard safety equipment prevents damage to valve and gate even if excess force applied in manual operation.
- One-touch auto/manual select
- Available in submersible and explosion-proof specifications.

Dimension drawings for LTKD-10B and LTMD-10B

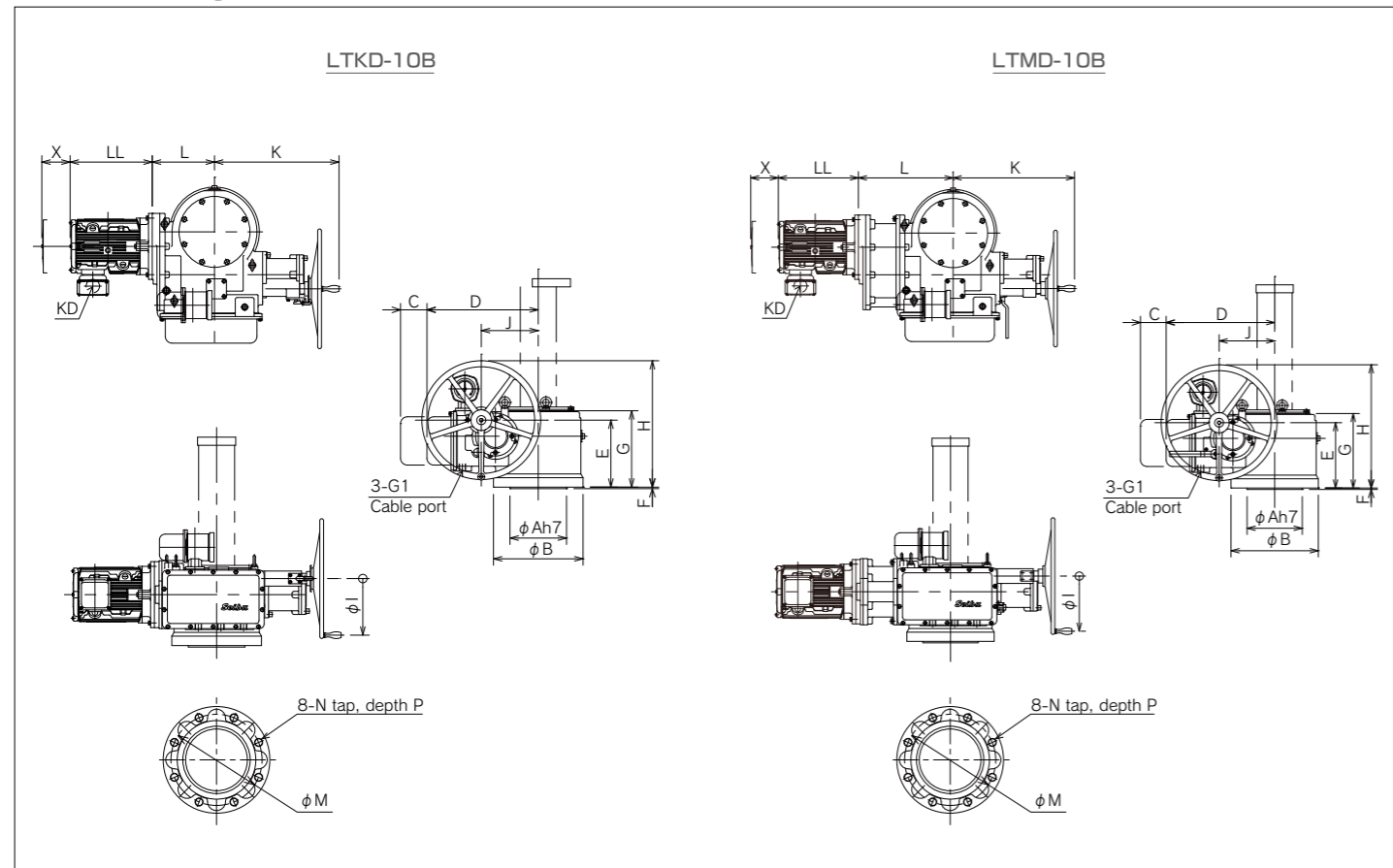

Specifications for LTKD-10B and LTMD-10B

Model	Allowable torque (Nm)	Allowable thrust (kN)	Allowable valve stem dia. (mm)		Sleeve speed min <sup>-1</sup> (50/60 Hz)	Motor	
			Rising stem	Non-rising stem		Power supply	Output kW
LTKD-10B LTMD-10B	12000	1100	115	135	10.6/12.8~63.1/75.7	Three-phase 200V class Three-phase 400V class (Please inquire for DC specifications)	7.5, 11, 15, 18.5, 22

Dimensions

Model	φA	φB	C	D	E	F	G	H	φI	J	K	L	φM	N	P
LTKD-10B	300	475	140	590	355	8	405	670	300	302	660	330	406	M36	70
LTMD-10B	300	475	140	590	355	8	405	670	300	302	660	515	406	M36	70

Motor output (kW)	7.5	11	15	18.5	22
KD/LL Without brake	G1 / 350	G1 / 435	G1 / 435	G2 / 488	G2 / 488
With brake	G1 / 467	G1 / 594	G1 / 594	G2 / 657	G2 / 657
Motor removal space X	100	150	150	150	150

※Please inquire for special installation or environmental requirements. (Vibration: Mechanism 1G max., electrical components exceeding 0.5G, noise, etc.)

Highly automated plants are running at faster speeds than ever, leading to rising demand for improvements in reliability and service life in output shafts of gate valves, globe valves and more.

The LTKB uses a ball screw instead of the conventional screw to significantly prolong service life and boost efficiency.

Features

- Excellent screw efficiency makes possible smaller, lighter drives and motors.
- The protection cylinder completely encloses the ball screw section.
- The valve stem screw remains in contact, achieving a transmission efficiency of 90% or higher.
- Low thread wear and long service life even in high-frequency operation.
- Note: Large-capacity designs for -1A, -3A and larger are also available. Inquire for details.

Dimension drawings

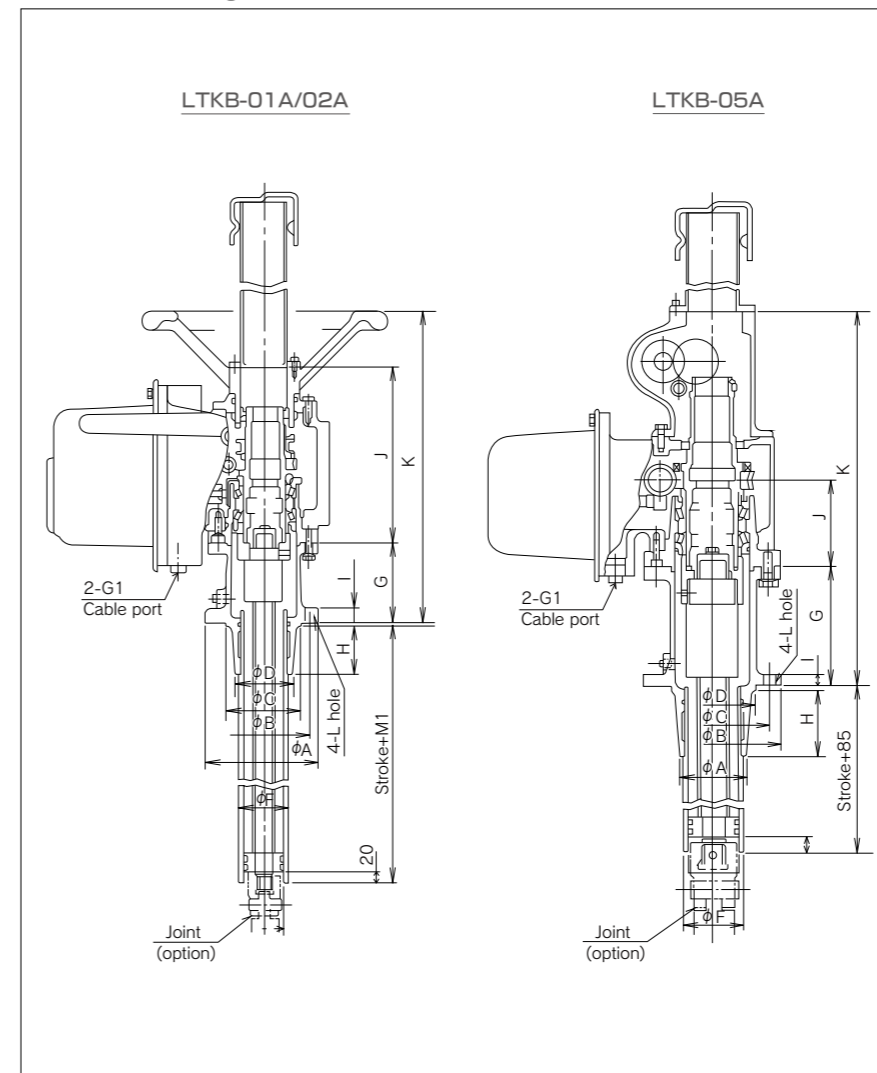

Specifications (Ball screw specifications require consultation. Inquire for details information.)

Model	Allowable torque (Nm)	Allowable thrust (kN)	Allowable valve stem dia. (mm)		Sleeve speed min <sup>-1</sup> (50/60 Hz)	Motor	
			Rising stem	Non-rising stem		Power supply	Output kW
LTKB-01A	250	45	-	30	10.0/12.0~67.5/81.0	Three-phase 200V class	0.1, 0.2, 0.4
LTKB-02A	450	65	-	42	10.0/11.9~62.5/75.0	Three-phase 400V class	0.2, 0.4, 0.75
LTKB-05A	850	105	-	75	10.0/12.0~67.5/81.0	(Please inquire for single-phase or DC specifications)	0.4, 1.5, 2.2

Dimensions

Model	φA	φB	φC	φD	φF	G	H	I	J	K	L	M1
LTKB-01A	175	140	100h7	90	65	125	75	15	242	407	φ12	40
LTKB-02A	210	165	130h7	110	85	150	85	20	277	497	φ15	47
LTKB-05A	300	254	200h7	120	94	200	95	20	140	625	φ19	85

※Please inquire for special installation or environmental requirements. (Vibration: Mechanism 1G max., electrical components exceeding 0.5G, noise, etc.)

## A small, lightweight, easy-to-handle actuator

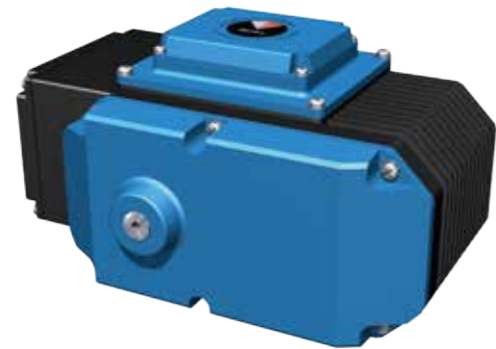

### Features

The body is made of aluminum and the cover of engineering plastic.

Inside, a worm gear/spur gear combination minimizes volume.

Terminal chamber is separated from switch to assure ample wiring space.

### Dimension drawings

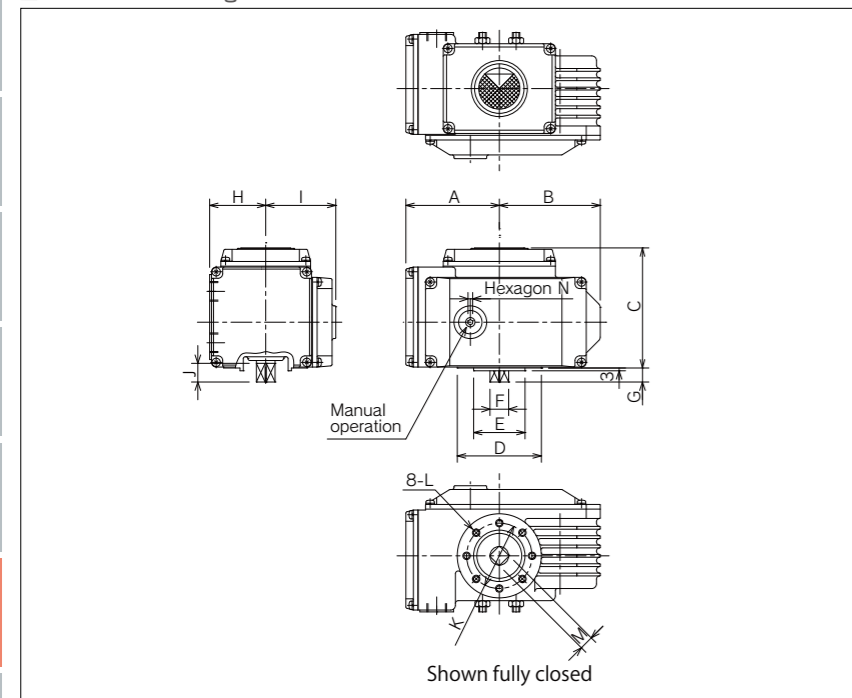

### Specifications

Model	SRH-007	SRH-020	SRH-060
Allowable output torque (Nm)	70	200	600
Open/close speed (sec/90°) 50/60 Hz	12/10•24/20		
Power supply (V)	Single-phase 100, 200		
Motor	Output (W)	10	40
	Insulation class	E	
	Thermal protector	Internal	
Space heater	8W		
Microswitch contact capacity	AC250V 5A		
Lead port	2-G1/2		
Ambient temperature	-10°C~50°C		
Protective construction	IP55/JPW55 (outdoor-use waterproofing)		
Terminals	Screw M3.5×12P		
Mass (kg)	4	8	15

### Dimensions

Model	A	B	C	D	E	F	G	H	I	J	K	L	M	N
SRH-007	100	108	128	φ90	φ55f8	φ20	15	60	75	20	70	M8	□15 <sup>+0.05</sup> <sub>-0.09</sub>	5
SRH-020	121	135	139	φ90	φ55f8	φ28	35	63	90	30	70	M8	□23 <sup>+0.06</sup> <sub>-0.11</sub>	6
SRH-060	158	164	164	φ125	φ70f8	φ39	40	85	133	35	102	M10	□30 <sup>+0.05</sup> <sub>-0.11</sub>	6

\*Please inquire for special installation or environmental requirements. (Vibration: Mechanism 1G max., electrical components exceeding 0.5G, noise, etc.)

## Completely waterproof compact actuator

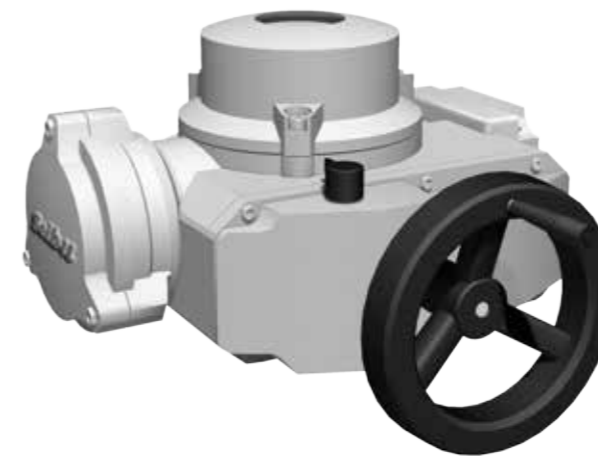

### Features

Waterproof terminal chamber with submersible IP68 construction.

Rich range of options, including angle transmitter, RI converter, and proportional control.

ExdII BT4 explosion-proof construction available.

Valve interface complies with ISO5211.



### Specifications

Model	SRJ-010	SRJ-020	SRJ-060	SRJ-1	SRJ-2
Allowable output torque (Nm)	125	250	600	1,000	2,000
Open/close speed (sec/90°) 50/60 Hz	9/7.5 18/15	18/15 36/30	18/15 36/30	18/15 36/30	36/30 72/60
Max. shaft dia. (mm)	28	28	42	60	60
Motor	Output (W)	40	40	100	200
	Supply voltage (V)	Three-phase 200, 400 Single-phase 100, 200			
	Insulation class	Class B			
	Brake	Permanent, with brake			
Thermal protector	Internal to motor				
Position limit switch	Microswitch RLS (1a1b), LLS (1a1b)				
Torque switch	Microswitch RTS (1a1b), LTS (1a1b)				
Manual operation	Automatic recovery, with handle				
Design life	10,000 cycles with valve load				
Terminals	Motor (M4-3P), control (M4-32P)				
Lead port	3-G1				
Pressure-resistant, explosion-proof	Exd II BT4 (option)				
Color	Standard paint (Munsell N8)				
Ambient temperature	-10°C~50°C				
Space heater	Included (PTC thermistor)				
Protective construction	IP68				
Mass (kg)	13	13	18	40	40

### Dimension drawings

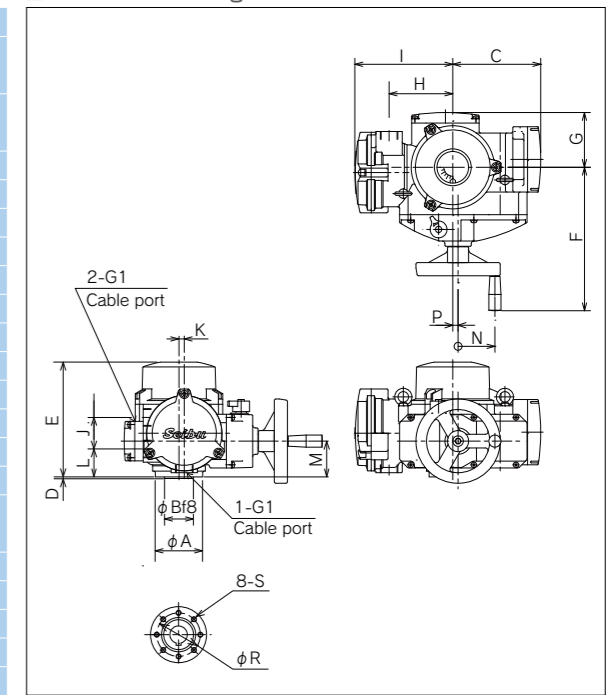

### Dimensions

Model	φA	φB	C	D	E	F	G	H	I	J	K	L	M	N	P	φR	S
SRJ-010																	
SRJ-020	90	55	167	3	218	281	104	121	186	56	10	64	68	70	10	70	M8
SRJ-060	125	70	191	3	235	325	130	136	202			60	65		8	102	M10
SRJ-1	175	100	267	4	296	363	191	174	240	60	0	111	141	110	70	140	M16
SRJ-2																	

\*Please inquire for special installation or environmental requirements. (Vibration: Mechanism 1G max., electrical components exceeding 0.5G, noise, etc.)



## Worm reducers also usable as motorized actuators

### Motorized type

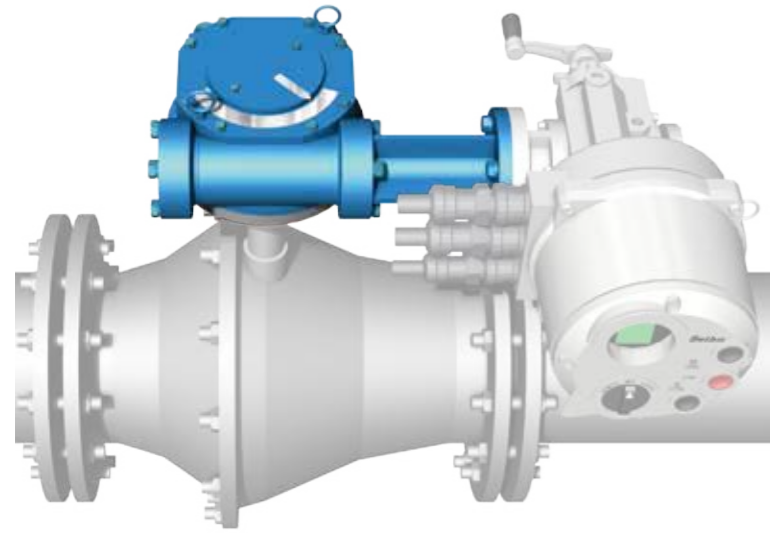

### Features

- Compact, lightweight design.
- At least 30% smaller and 20% lighter than our previous design.
- Outstanding resistance to corrosion and environmental deterioration.
- More variations than ever for the optimal specifications.
- Valve interface complies with ISO5211.
- The gear case is made of tough ductile casting, the worm gear of heat-treated structural-use carbon steel, and the worm wheel of wear-resistant aluminum-brass alloy.

### Manual type



## Butterfly valve application example

Model: Semflex-VM-01 / BRM-3F



Note: We do not manufacture or sell valves.

Model: LTKD-05 / BRM-10F

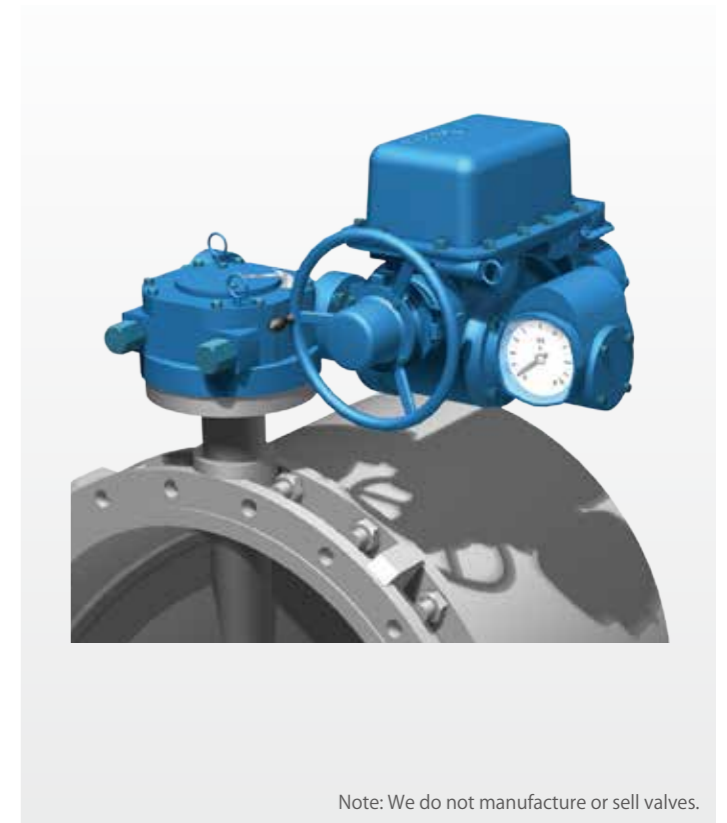

Note: We do not manufacture or sell valves.



### BRM series basic specifications







Model	BRM-1			BRM-2			BRM-3			BRM-4			BRM-5			BRM-10					BRM-18					BRM-40					BRM-80					BRM-150																						
	Standard	-1S	-1B	Standard	-1S	-1B	Standard	-1S	-1B	Standard	-1S	-1B	Standard	-1S	-1B	Standard	-1S	-1B	-2S	-2B	Standard	-1S	-1B	-2S	-2B	-3B	Standard	-1S	-1B	-2S	-2B	-3B	Standard	-1S	-1B	-2S	-2B	-3B																				
Input type	Motorized:F			Manual:H			Motorized:F			Manual:H			Motorized:F			Manual:H			Motorized:F					Manual:H					Motorized:F					Manual:H																								
Output specifications	Allowable torque (Nm)	1,000			2,000			3,000			4,000			5,000			10,000					18,000					40,000					80,000					150,000																					
	Gear ratio	1/40	1/80	1/80	1/60	1/150	1/150	1/60	1/150	1/150	1/60	1/150	1/150	1/60	1/150	1/150	1/60	1/180	1/180	1/540	1/450	1/60					1/60					1/65					1/65																					
	Output flange bolt size Bolt tightening torque	F12, M12, 32Nm			F14, M16, 76Nm			F16, M20, 121Nm			F16, M20, 162Nm			F20, M16, 65Nm			F20, M16, 65Nm					F30, M20, 201Nm					F35, M30, 562Nm					F40, M36, 1,182Nm					F48, M36, 1,242Nm																					
Allowable valve rod dia. (mm)	38			50			60			75			75			100 (95)					115 (110)					150 (145)					180					220																						
Mechanical advantage (reduction ratio x efficiency)	12	23.3	23.3	18	43.7	43.7	18	43.7	43.7	18	43.7	43.7	18	43.7	43.7	18	52.4	52.4	152.4	127	18	69.8	69.8	271	203.2	657.1	19.5	75.7	75.7	293.6	220.2	854.3	19.5	94.6	94.6	458.7	367	1,335																				
Input shaft	Torque (Nm)	83.3			42.9			111.1			45.8			45.8			166.7			68.7			68.7			222.2			91.6			91.6			277.8			114.5			114.5			555.6			190.9			190.9			65.6			78.7		
	Speed (Rev)	10			20			15			37.5			37.5			15			37.5			37.5			15			45			45			135			112.5			15			45			45			135			112.5					
Mass (kg)	13	17.5	19.5	25	24	22	27.5	26.5	34.5	42.5	45.5	37.5	45.5	48.5	66.5	85	95.5	98	96	116	137	145	153	148	202	232	247	255	261	266	397	443	489	480	472	510	867	989	1,060	1,090	1,034	1,120																

1 The valve drive torque should be set within the allowable BRM torque.  
 2 Use 1 or 2 keys to connect to the valve stem as appropriate. Values in parentheses are for old-style JIS key.  
 3 Input types marked "X" are also available. Inquire for details.  
 4 Mechanical advantage is the ratio between input-shaft torque and output-shaft torque (for efficiency, worm gear: 0.3, spur/bevel gear: 0.97).  
 5 Input-shaft torque shown for an output-shaft torque within the allowable torque.  
 6 Before attaching the BRM to a valve, please ensure that the strength class of the bolts is at least 10.9, and the length of engagement sufficient. Torque value shown in the minimum.

Note: The above values are subject to change without notice.

\*Please inquire for special installation or environmental requirements. (Vibration: Mechanism 1G max., electrical components exceeding 0.5G, noise, etc).

Electronic actuators		Manual recovery	Automatic recovery	Max. torque Nm	Max. thrust kN	Max. shaft dia. mm		Transmitter specifications				Network (PROFIBUS)	Inverter (variable speed)	Waterproofing		
						Rod	Screw	Synchro	Resistance (potentiometer)	DC4~20mA output	DC4~20mA I/O			IP55	IP67	IP68
<b>Semflex-A</b> 	Multi-turn motorized	A-50	—	50	25	28	30	—	—	○	○	○	○	—	—	○
		A-100	—	100	54	38	40	—	—	○	○	○	○	—	—	○
<b>Semflex-VM</b> 		VM-007	—	70	70	34	40	—	—	○	○	○	○	—	—	○
		VM-01	—	150	70	34	40	—	—	○	○	○	○	—	—	○
		VM-04	—	550	130	50	58	—	—	○	○	○	○	—	—	○
		VM-07	—	850	160	60	72	—	—	○	○	○	○	—	—	○
		VM-1	—	1,800	270	80	95	—	—	○	○	○	○	—	—	○
<b>Semflex-VP</b> 		Partial-turn motorized	—	VP-010	125	—	28	—	—	○	○	○	○	—	—	○
			—	VP-020	250	—	28	—	—	○	○	○	○	—	—	○
			—	VP-060	600	—	42	—	—	○	○	○	○	—	—	○
	—		VP-1	1,000	—	60	—	—	○	○	○	○	—	—	○	
	—		VP-2	2,000	—	60	—	—	○	○	○	○	—	—	○	

Mechanical actuators		Manual recovery	Automatic recovery	Allowable torque Nm	Allowable thrust kN	Allowable valve stem dia. mm		Transmitter specifications				Network (PROFIBUS) ※2	Inverter (variable speed) ※2	Waterproofing		
						Rod	Screw	Synchro	Resistance (potentiometer)	DC4~20mA output	DC4~20mA I/O			IP55	IP67	IP68
<b>Semflex-VMM</b> 	Multi-turn motorized	VMM-007		70	70	34	40	—	—	○	○	○	—	—	○	
		VMM-01		150	70	34	40	—	—	○	○	○	—	—	○	
		VM-04		550	130	50	58	—	—	○	○	○	—	—	○	
		VM-07		850	160	60	72	—	—	○	○	○	—	—	○	
		VM-1		1,800	270	80	95	—	—	○	○	○	—	—	○	
<b>LTRH LTRM</b> 		LTRH-01	LTRM-01	120	38	28	30	○	○	○	—	—	—	○	—	—
		<b>LTKD/LTMD series</b> 	LTKD-01	LTMD-01	250	45	28	30	○	○	○	○	—	—	○	○
LTKD-02			LTMD-02	450	65	40	42	○	○	○	○	—	—	○	○	○
LTKD-05			LTMD-05	850	105	50	52	○	○	○	○	—	—	○	○	△(MD)
LTKD-1			LTMD-1	1,750	200	62	70	○	○	○	○	—	—	○	○	△(MD)
LTKD-3	LTMD-3		4,000	320	80	90	○	○	○	○	—	—	○	○	△(MD)	
LTKD-5	LTMD-5		6,500	500	100	115	○	○	○	○	—	—	○	○	△(MD)	
LTKD-10B	LTMD-10B		12,000	1,100	115	135	○	○	○	○	—	—	○	○	△(MD)	
<b>SRH series</b> 	—	SRH-007	70	—	□15 <sup>-0.05</sup> / <sub>-0.09</sub>		—	○	○	○	—	—	○	—	—	
	—	SRH-020	200	—	□23 <sup>-0.06</sup> / <sub>-0.11</sub>		—	○	○	○	—	—	○	—	—	
	—	SRH-060	600	—	□30 <sup>-0.05</sup> / <sub>-0.11</sub>		—	○	○	○	—	—	○	—	—	
<b>SRJ series</b> 	Partial-turn motorized	—	SRJ-010	125	—	28	—	○	○	○	○	—	—	—	○	
		—	SRJ-020	250	—	28	—	—	○	○	○	○	—	—	○	
		—	SRJ-060	600	—	42	—	—	○	○	○	○	—	—	○	
		—	SRJ-1	1,000	—	60	—	—	○	○	○	○	—	—	○	
		—	SRJ-2	2,000	—	60	—	—	○	○	○	○	—	—	○	
<b>BRM series</b>  (Manual)  (Auto)	Partial turn auto/manual	BRM-1		1,000	—	38	—					—	—	○	○	
		BRM-2		2,000	—	50	—					—	—	○	○	
		BRM-3		3,000	—	60	—					—	—	○	○	
		BRM-4		4,000	—	75	—					—	—	○	○	
		BRM-5		5,000	—	75	—					—	—	○	○	
		BRM-10		10,000	—	100(95)	—					—	—	○	○	
		BRM-18		18,000	—	115(110)	—					—	—	○	○	
		BRM-40		40,000	—	150(145)※1	—					—	—	○	○	
		BRM-80		80,000	—	180 ※1	—					—	—	○	○	
		BRM-150		150,000	—	220 ※1	—					—	—	○	○	

※1 Values in parentheses are for old-style JIS key.

※2 Inquire for information on manual actuators equipped with network communication or inverters.

※Please inquire for special installation or environmental requirements. (Vibration: Mechanism 1G max., electrical components exceeding 0.5G, noise, etc.)



**Full support to keep your system running smoothly!**

Actuators must be maintained to ensure that they function when they're needed, especially in emergency situations. Expert technology and long experience means that inspections are performed as dictated by the specifics of each installation, backed up by emergency repairs as required.

**Service Locations**

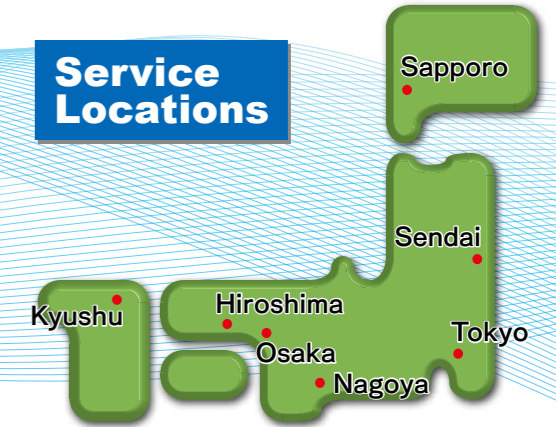

**Warranty period**

One year from product shipment

Any manufacturing defects will be handled free of charge during the warranty period.

**Class A inspection**

1-5 years from product shipment

On-site inspection of external appearance, operating circuits, insulation, etc.

**Class B inspection**

5-7 years from product shipment

Class A inspection, plus inspections of control mechanisms and gears.

**Class C inspection**

7-10 years from product shipment

Disassembly at our plant, with parts replacement and repairs as needed.

**Emergency response**

Prompt investigation and repair as needed in emergency situations.

**Maintenance engineering (ME) to prevent trouble before it happens, for heightened reliability!**



Eliminating mechanical breakdown promotes smooth operation and slashes cost.



Detecting and rectifying minor problems before they interfere with operation.

Electrical insulation measurement



Limit switch inspection



Grease removal



Internal gear check



Disassembly and inspection



Reassembly and testing



Emergency investigation



Motor replacement



**A variety of deterioration occurs inside the mechanical system over time**



Limit switch contacts deteriorate, making it impossible for the system to stop at the specified location.



Lubricant solidifies, eliminating all lubrication function.



Torque microswitch contacts fuse, making it impossible to stop the actuator in emergencies.





## Seibu valve actuators are inspected with care, one at a time, before delivery.

Our actuators are utilized in a host of systems demanding precise, reliable control of water, electricity, gas, petroleum, and more, and because they are such critical components, actuators must deliver safe, accurate action. Every part purchased for use in a Seibu actuator, or manufactured in our own shops, is stringently tested, and each completed actuator assembly tested again before shipment.

### Parts receiving



### Processing and assembly



### Inspection



### Shipment



# — Request for quote —

Number of sheets: \_\_\_\_\_

To: **Seibu Electric & Machinery Co., Ltd.**

(Date: / / )

FAX Tokyo Branch (03)5628-0023 FAX Hiroshima Sales Office (082)545-1618  
 Osaka Branch (06)4796-6707 Sapporo Sales Office (011)221-3392  
 Nagoya Sales Office (052)800-5030 Sendai Sales Office (022)797-6696  
 Kyushu Sales Office (092)941-1522

Company name:			
Dept.		Contact name:	
Tel:		Fax:	

1 Industry	<input type="checkbox"/> Waterworks/sewerage	<input type="checkbox"/> Electric power	<input type="checkbox"/> Steelmaking
	<input type="checkbox"/> Petroleum, industrial chemicals	<input type="checkbox"/> Waterways	<input type="checkbox"/> Other
2 Place of delivery			
3 Valve type	<input type="checkbox"/> Butterfly	<input type="checkbox"/> Gate valve	<input type="checkbox"/> Gate <input type="checkbox"/> Other
4 Specification dia.			
5 Specification objective	<input type="checkbox"/> On/off	<input type="checkbox"/> Flow control	
	<input type="checkbox"/> Other ( )		
6 Standards compliance	<input type="checkbox"/> Manufacturer standard	<input type="checkbox"/> Other ( )	
7 Installation site	<input type="checkbox"/> Outdoors	<input type="checkbox"/> Indoors	
8 Waterproofing	<input type="checkbox"/> IP55	<input type="checkbox"/> IP67	<input type="checkbox"/> IP68
9 Explosion-proofing, etc.	<input type="checkbox"/> Standard	<input type="checkbox"/> d2G4	<input type="checkbox"/> Exd II BT4
10 Supply power	Drive power ( ) Eg. Triple-phase 200V 50Hz		
	Control power <input type="checkbox"/> Single-phase 200V class <input type="checkbox"/> Single-phase 100V class <input type="checkbox"/> No supply		
	<input type="checkbox"/> Other ( )		
11 Actuator specification	<input type="checkbox"/> Manual recovery	<input type="checkbox"/> Automatic recovery	
12 Required torque, load			
13 Open/close speed	<input type="checkbox"/> Manufacturer standard	<input type="checkbox"/> Other ( )	
14 Paint specification	<input type="checkbox"/> Manufacturer standard	<input type="checkbox"/> Other ( )	

### Comments and questions

---



---



---



---



---